

DOCUMENT RESUME

ED 178 269

SE 028 462

AUTHOR Hathway, James A., Ed.  
 TITLE Individualized Testing System: Performance Checks, ISCS Level I, Form B.  
 INSTITUTION Florida State Univ., Tallahassee. Curriculum Study Center.  
 SPONS AGENCY National Science Foundation, Washington, D.C.  
 PUB DATE 73  
 NOTE 71p.; For related documents, see SE 028 460-488

EDRS PRICE MF01/PC03 Plus Postage.  
 DESCRIPTORS Academic Achievement; Course Evaluation; Elementary, Secondary Education; \*Evaluation; \*Individualized Programs; Junior High Schools; \*Performance Tests; \*Science Course Improvement Project; Science Education; Science Materials; Science Tests; \*Student Evaluation

IDENTIFIERS \*Intermediate Science Curriculum Study; \*National Science Foundation

ABSTRACT

This is one form of three performance checks booklets (A, B, and C) for level I of the Intermediate Science Curriculum Study (ISCS). The three booklets are considered one of four major subdivisions of a set of individualized evaluation materials for level I of the ISCS. This booklet (form B), developed to assess the students' achievement of the objectives of level I, contains a set of performance checks which are equivalent to the performance checks of the other two forms (A and C). Each performance check has its own code number which indicates the unit number and identifies whether it is based on core material or excursions. Directions for students' use of performance checks are also included. (HM)

\*\*\*\*\*  
 \* Reproductions supplied by EDRS are the best that can be made \*  
 \* from the original document. \*  
 \*\*\*\*\*



**INTERMEDIATE  
SCIENCE  
CURRICULUM  
STUDY**

ED178269

U S DEPARTMENT OF HEALTH,  
EDUCATION & WELFARE  
NATIONAL INSTITUTE OF  
EDUCATION

THIS DOCUMENT HAS BEEN REPRODUCED EXACTLY AS RECEIVED FROM THE PERSON OR ORGANIZATION ORIGINATING IT. POINTS OF VIEW OR OPINIONS STATED DO NOT NECESSARILY REPRESENT OFFICIAL NATIONAL INSTITUTE OF EDUCATION POSITION OR POLICY.

**INDIVIDUALIZED  
TESTING  
SYSTEM**

"PERMISSION TO REPRODUCE THIS MATERIAL HAS BEEN GRANTED BY

Mary L. Charles  
NSF

TO THE EDUCATIONAL RESOURCES INFORMATION CENTER (ERIC)."

**Performance Checks**  
**ISCS LEVEL I**  
**FORM B**



**SILVER BURDETT  
GENERAL LEARNING CORPORATION**

Morristown, New Jersey • Park Ridge, Ill. • Palo Alto • Dallas • Atlanta



Full Text Provided by ERIC

## INDIVIDUALIZED TESTING SYSTEM

- ALL LEVELS** Individualizing Objective Testing (an ITP module)  
Evaluating and Reporting Progress (an ITP module)
- LEVEL I** Performance Objectives, ISCS Level I  
Performance Checks, ISCS Level I, Forms A, B, and C  
Performance Assessment Resources, ISCS Level I, Parts 1 and 2
- LEVEL II** Performance Objectives, ISCS Level II  
Performance Checks, ISCS Level II, Forms A, B, and C  
Performance Assessment Resources, ISCS Level II, Parts 1 and 2
- LEVEL III** Performance Objectives, ISCS Level III  
Performance Checks, ISCS Level III, ES-WB, Forms A, B, and C  
WY-Y-IV, Forms A, B, and C  
IO-WU, Forms A, B, and C  
WW-CP, Forms A, B, and C  
Performance Assessment Resources, ISCS Level III, ES-WB  
WYY-IV,  
IO-WU  
WW-CP

### ACKNOWLEDGMENTS

The work presented or reported herein was supported by funds provided by the National Science Foundation. However, the opinions expressed herein do not necessarily reflect the position or policy of the National Science Foundation, and no official endorsement by the agency should be inferred.

©1973 THE FLORIDA STATE UNIVERSITY

All rights reserved. Printed in the United States of America. Published simultaneously in Canada. Copyright is claimed until 1978. Except for the rights to materials reserved by others, the Publishers and the copyright owner hereby grant permission to domestic persons of the United States and Canada for use of this work without charge in the English language in the United States and Canada after 1978 provided that the publications incorporating materials covered by the copyrights contain an acknowledgment of them and a statement that the publication is not endorsed by the copyright owner. For conditions of use and permission to use materials contained herein for foreign publications in other than the English language, apply to the copyright owner. This publication, or parts thereof, may not be reproduced in any form by photographic, electrostatic, mechanical, or any other method, for any use, including information storage and retrieval, without written permission from the publisher.

ILLUSTRATIONS: ©1973 GENERAL LEARNING CORPORATION  
ALL RIGHTS RESERVED.

## **ISCS STAFF**

David D. Redfield, Co-Director  
William R. Snyder, Co-Director  
Ernest Burkman, Steering Committee Chairman

Robert L. Cocanougher, Art Director  
Stewart P. Darrow, Teacher Education  
George O. Dawson, Teacher Education  
Cheval Fagan, Artist  
Ronald N. Giese, Evaluation  
James A. Hathway, Editor  
Adrian D. Lovell, Administration and Field Trial Coordinator  
Janet Mauney, Artist  
Lynn H. Rogers, Artist  
Millicent Shargel, Grammarian  
Stephen C. Smith, Artist  
Lois S. Wilson, Assistant Editor

## **MATERIALS DEVELOPMENT CONTRIBUTORS**

Betsy Conlon Balzano, State University of New York at Brockport  
Thomas Boehm, State University of New York at Albany  
Linda Dubaldi, F.S.U.  
William H. Fletcher, F.S.U.  
John R. Hassard, Georgia State University  
H. Dale Luttrell, North Texas State University  
Mildred MacMullen, Hudson, New York  
E. Wesley McNair, F.S.U.  
Luis A. Martinez-Perez, F.S.U.  
Charles Mielcarski, Averill Park, New York  
Lawrence E. Oliver, F.S.U.  
Barney Parker, F.S.U.  
Everett S. Stallings, F.S.U.  
Paul H. Westmeyer, F.S.U.

## FOREWORD

To implement an educational approach successfully, one must match the philosophy of evaluation with that of instruction. This is particularly true when individualization is the key element in the educational approach. Yet, as important as it is to achieve this match, the task is by no means simple for the teacher. In fact, without specific resource materials to help him, he is apt to find the task overwhelming. For this reason, ISCS has developed a set of individualized evaluation materials as part of its Individualized Teacher Preparation (ITP) program. These materials are designed to assist teachers in their transition to individualized instruction and to help them tailor their assessment of students' progress to the needs of all their students.

The two modules concerned with evaluation, *Individualizing Objective Testing and Evaluating and Reporting Progress*, can be used by small groups of teachers in in-service settings or by individual teachers in a local school environment. Hopefully, they will do more than give each teacher an overview of individualized evaluation. These ITP modules suggest key strategies for achieving both subjective and objective evaluation of each student's progress. And to make it easier for teachers to put such strategies into practice, ISCS has produced the associated booklets entitled *Performance Objectives*, *Performance Assessment Resources*, and *Performance Checks*. Using these materials, the teacher can objectively assess the student's mastery of the processes, skills, and subject matter of the ISCS program. And the teacher can obtain, at the moment when they are needed, specific suggestions for remedying the student's identified deficiencies.

If you are an ISCS teacher, selective use of these materials will guide you in developing an individualized evaluation program best suited to your own settings and thus further enhance the individualized character of your ISCS program.

The Co-Directors  
Intermediate Science Curriculum Study  
Rm 4J5, W.H. Johnston Building  
415 North Monroe Street  
Tallahassee, Florida 32301

## NOTES TO THE STUDENT

Now that you have completed several chapters, excursions, and self-evaluations, you are ready to help your teacher determine how well you are doing. The performance checks in this book will provide your teacher with this information. Then your teacher can help you with things you may not understand and can keep a record of your progress.

Read the next section carefully. It explains some important things about the performance checks in this book, and it gives you specific suggestions for using them.

### What You Need to Know about Performance Checks

1. You do performance checks when you are ready. Performance checks are somewhat like the questions in the self-evaluations – you do them when you are ready, not when the whole class is ready.

2. Your teacher or both of you decide how many you do. Your teacher or you and your teacher together will decide which ones you should do. You are not expected to do all of the performance checks.

3. There are three forms for each performance check. Every performance check is written in three forms – A, B, and C. (The title of this booklet tells you whether it is Form A, B, or C.) Usually the answers for each form are different. When you do a check, you will use only one form. The A, B, and C forms are always in different booklets. Within each booklet all the performance objectives for the same unit are listed together. These units are in numerical order. Each unit has performance checks based on core material and performance checks based on excursions.

4. Each performance check has its own number. The number is in the outside margin of the page and will look like this: 03-Core-17A or 05-Exc 17-2A. These numbers mean

<u>03</u>	-	<u>Core</u>	-	<u>17</u>	A	and	<u>05</u>	-	<u>Exc</u>	<u>17</u>	-	<u>2</u>	A
unit		based on core material		check number	form of the check		unit		based on the excursion material	excursion number		check number	form of the check

5. Each performance check is separated from the other. There is a line before each performance check and one after it. Some performance checks have several parts, so do everything called for between the lines. When there is no line at the bottom of a page, you can expect to find the check continued onto the next page.

6. Sometimes you will need to use equipment. If special materials are needed, they will be in boxes labeled with the same number and sometimes the same letter too as the performance check for which you need them.

7. Some performance checks have two or more answers. If more than one answer is correct, you must select all the correct choices. In such cases selecting just one answer is not enough.

8. Some performance checks have no answers. Occasionally, you may be asked to do something that is impossible and to explain your answer. If so, say that the task is impossible and explain why.

9. You share books of performance checks and **YOU DO NOT WRITE IN THEM.** Write your answers on other paper. Give the number and form of the performance check for each answer you write. If you are to draw a graph, your teacher may provide you with grid paper.

10. Your teacher or his assistant will collect and mark your checks. And sometimes you must ask him to watch or assist you as you do a check.

11. Sometimes a review procedure will be suggested. If you can't do a performance check, you may be asked to review a part of the text or a self-evaluation question. You may then be checked on the same material, so be sure you understand the material you review. Get help if you need it.

Get two test leads, a bulb, a socket, and an ISCS battery from your teacher. Charge the battery for one minute. Get your teacher to watch you. Now connect the bulb to the battery so that the bulb lights.

01-Core-1B

How would you connect the bulb-socket to the battery shown below to make the bulb light? Write the two numbers for each test lead that show where the ends of each lead should be connected.

01-Core-2B

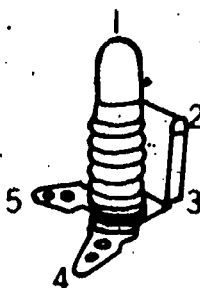
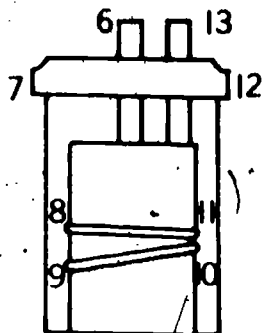

Something that changes in an activity and affects the results of the activity is called

01-Core-3B

- a problem.
- a variable.
- a data table.
- a conclusion.

In box 01-Core-4B you will find a circuit that is all set up. Use the good spare parts in the box to find out why the bulb doesn't light. Which part is bad?

01-Core-4B

Get batteries A, B, and C from box 01-Core-5. Use any other materials you think you need. Which of the batteries has influence?

01-Core-5B

A clock spring transfers influence to the hands of a clock. Why must you wind the clock spring before it can make the clock hands move?

01-Core-6B

Match the following terms by first listing the numbers (1, 2, and 3) on your paper and then writing after each number the letter (a, b, c, or d) of the correct matching definition.

01-Core-7B

Terms

1. System
2. Subsystem
3. Component

Definitions

- a. Any object that is part of a system
- b. An object that does not interact with other objects
- c. A group of objects that interact with each other
- d. A group of objects that directly interact with each other within a system



01-Core-8B

On your paper, write the letter of each diagram which identifies a system. Also explain why the diagram or diagrams you chose represent systems.

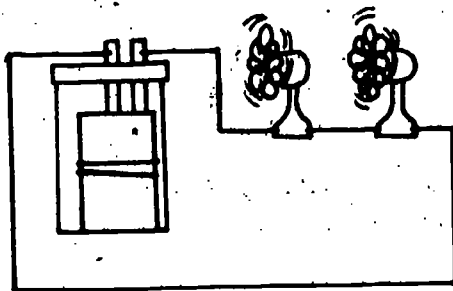

Diagram a

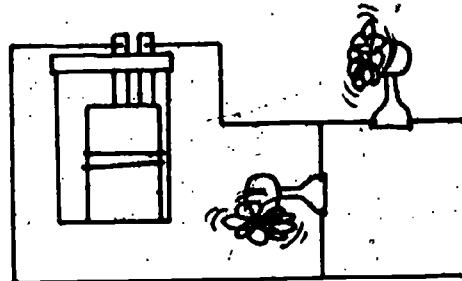

Diagram b

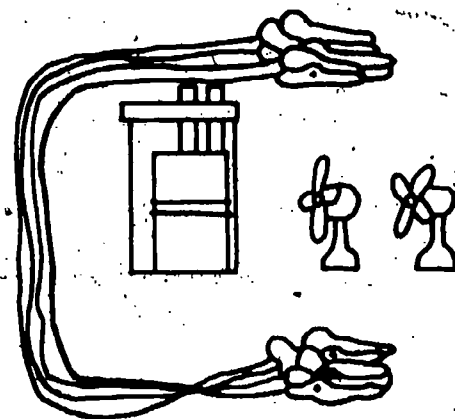

Diagram c

01-Core-9B

A

C

E

D

B

F

On the diagram above, measure the distance between the following points to the nearest 0.1 cm.

1. What is the distance from point A to point F?
2. What is the distance from point C to point D?
3. What is the distance from point B to point C?

01-Core-10B

Fill a beaker nearly full of water. Ask your teacher or his assistant to pour the water for you. Tell him when to begin. Use your ISCS timer to find out how long he takes to pour water from the beaker.

01-Core-11B

On your paper write the letters of all good reasons for using data tables.

- a. Data tables list the data in a given order.
- b. Data tables by organizing the data help to reduce errors.
- c. Data tables make it easier to find how one variable affects another.
- d. Data tables make sure you collect the same data for each set of measurements.
- e. All of these.

Name of Group Member	No. of Sinkers Dragged	No. of Times Dragged	Distance from Hook to Pulley (cm)	Total Distance Dragged (cm)	Total Time for Dragging (sec)
Sue	1	70	90	6300	130
Betty	2	60	85	5100	110
Sam	3	50	80	4000	105

Study the table. Then answer all of the following questions.

1. What was the distance in centimeters from hook to pulley when three sinkers were dragged?
2. What was the total distance in centimeters that Betty's battery dragged two sinkers?
3. How many times was one sinker dragged?

Write the letter of the phrase below which correctly completes the sentence. An operational definition includes a description of \_\_\_\_ the thing being defined.

01-Core-13B

- a. the shape and luster of
- b. the color or odor of
- c. the way to measure
- d. the way to classify

On your paper, divide 21.34 by 12.1. Round off your answer to one number after the decimal point.

01-Core-14B

On your paper, multiply 8.22 by 1.4.

01-Core-15B

Add these three numbers on your paper. 2.21, 3.44, 1.5

01-Core-16B

Subtract 7.88 from 9.9 on your paper.

01-Core-17B

Your teacher will observe you for this check when he can.

01-Core-18B

Your teacher will observe you for this check when he can.

01-Core-19B

Your teacher will observe you for this check when he can.

01-Core-20B

Your teacher will observe you for this check when he can.

01-Core-21B

Your teacher will observe you for this check when he can.

01-Core-22B

01-Exc 01-1B

Which of the following tells the main advantage of the metric system which makes it useful in measurement problems?

- a. Worldwide use of the metric system would aid world trade more than worldwide use of the English system.
- b. The units of the metric system are related by factors of the number ten, and therefore changing from one unit to another is easier.
- c. The meter has a more reasonable historical basis than the yard.
- d. The metric system is more accurate than the English system.

01-Exc 01-2B

The measurement system that is used in ISCS science is the

- a. English system.
- b. Metric system.
- c. Roman system.
- d. Egyptian system.

01-Exc 03-1B

In Excursion 3, you studied two forces — lift and drag — acting on two sinkers. One force was greater than the other. You found this by making the two forces act directly on each other. Read the two examples below. Which one makes a direct comparison of the two variables?

- a. Jack pulled a box of bricks and moved it. Jim pulled a box of rocks and moved it. Who can pull harder?
- b. Jack and Jim pulled on opposite ends of a rope against each other. Who can pull harder?

Which of the following is an operational definition?

02-Core-1B

- a. A ruler is a device for measuring length.
- b. A lariat is a long, light rope with a noose, used to catch livestock.
- c. Radioactivity is a flow of particles or energy from unstable atoms. The particles or energy cause a Geiger counter to click. The amount of the radioactivity is shown by the number of clicks of the Geiger counter per second.

Imagine that everyone in your science class used the scale that he marked in washer units.

02-Core-2B

1. Would this cause a problem during the school year?
2. Why or why not?

Suppose you were asked to weigh a straight pin with your force measurer. List the letters of all of the things below that you would need for your force measurer.

02-Core-3B

- a. A longer scale card
- b. A scale card calibrated from 0 N to 0.1 N
- c. A very thin blade
- d. A thicker blade

Get an ISCS force measurer, 2 blades, paper clips, and a newton scale card from the supply area. From your teacher, get a spinning disk and an electricity measurer base. Report to your teacher how much the spinning disk weighs and how much the electricity measurer base weighs.

02-Core-4B

Get box 02-Core-5B from the supply area. Use an ISCS force measurer, the newton scale card, an aluminum cup, and paper clips to weigh each of the two objects. On your paper, write the difference in newtons between the weights.

02-Core-5B

Jack weighed some sinkers he brought from home on his force measurer. He added the sinkers one at a time to a hook on the end of the force measurer blade. Then, he filled in the data table below.

02-Core-6B

Number of Sinkers on Hook	Total Weight of Sinkers (in newtons)
1	0.9
2	1.7
3	2.4
4	3.3
5	4.2
6	4.8

State what the table tells you about the weights of the sinkers.

**02-Core-7B**

Marvin did Excursion 3, which compares weight and drag. On a separate piece of graph paper, label the axes as shown below. Then construct a graph of Marvin's data, listed in the table below. The table shows the dragging power of the dropping sinkers. Draw a best-fit line for the plotted points.

Sinkers Dropped	Sinkers Dragged
1	2
3	6
5	10
6	12

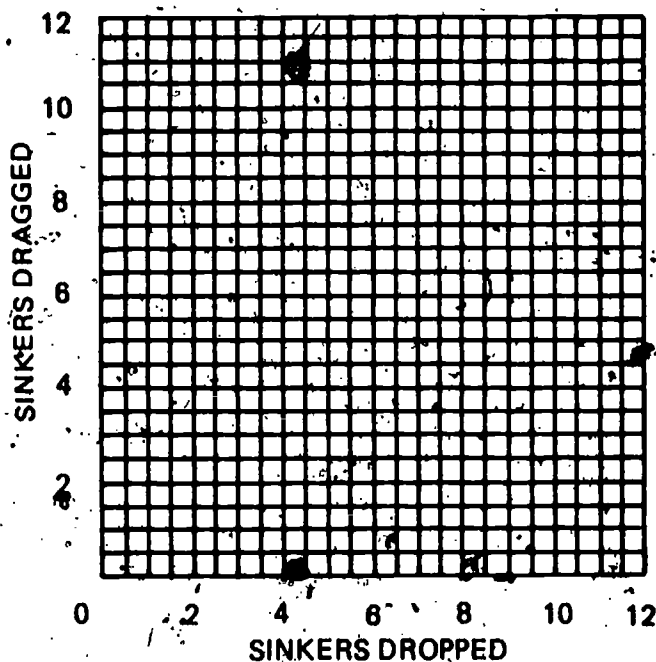
**02-Core-8B**

Write an operational definition for *weight*, using an ISCS force measurer in your definition.

**02-Core-9B**

Ask your teacher for a force measurer with an aluminum pin in it. Do not remove the pin.

Answer the following questions by listing the numbers (1, 2, and 3) on your paper and writing after each number the answer to the corresponding question.

1. Does the force measurer have the thin or thick blade attached to it?
2. What is the number of the hole the pin is in?
3. How much force is on the aluminum pin?

**02-Core-10B**

From your teacher, get force measurer scale card 02-Core-10B. Use your force measurer with the thin blade to weigh a sinker. Have your teacher watch you. Report the weight in the units shown on the scale card.

**02-Core-11B**

On your paper, write the name of the metric unit which you use in ISCS for measuring force.

**02-Core-12B**

On your paper, write the words that complete the sentence below.

If you want to know if a force is acting on a tennis ball, you would look for changes in the ball's \_\_\_\_\_ or \_\_\_\_\_.

Get a compass and a heavy washer from the supply area. Set the compass on your desk. Bring the heavy washer very near to the compass from three different directions. Watch what happens.

02-Core-13B

1. Is there a force acting between the heavy washer and the compass?
2. How do you know?

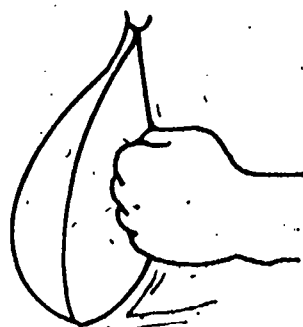

Diagram a

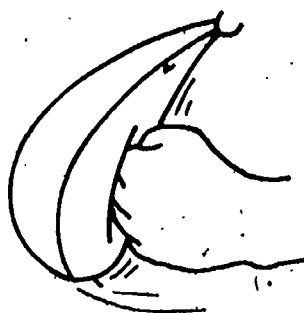

Diagram b

02-Core-14B

The two punching bags being struck are alike.

1. Which diagram shows the greater amount of force being applied?
2. How do you know?

Write an operational definition for *force*. Remember, an operational definition answers two questions.

02-Core-15B

Suppose you wanted to write an operational definition for something. What two questions would you have to answer about it?

02-Core-16B

A cup with four washers in it is attached to the blade of a force measurer. Name the kind of force acting on the blade of the force measurer, causing it to bend down.

02-Core-17B

When a large book is carefully placed on a paper cup and then released, the cup is crushed. What force causes the change in the shape of the cup?

02-Core-18B

It would be very difficult to define operationally terms such as *love* or *honor*. State two reasons why this is so.

02-Core-19B

Look at the diagrams of the measuring instruments. What needs to be added to them so that you could tell your teacher your measurement without having to show him the measuring cup or the meterstick?

02-Core-20B

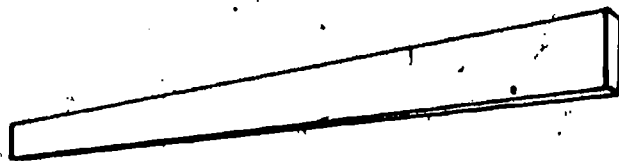

Meterstick

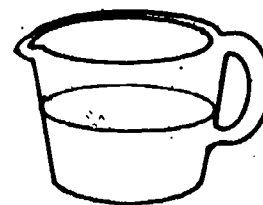

Measuring cup

**02-Core-21B**

Tie or tape a string to a magnet as shown below. Hang the magnet on the thick force measurer blade. Measure the combined weight of the magnet and string. Number and record your results for each step of the following.

1. Record the combined weight of the magnet and string.
2. Attach a screw head to the magnet as shown. Pull gently on the screw until the magnet releases it. What is the force measurer reading when the magnet releases the screw?
3. How much force did the magnet exert on the screw?

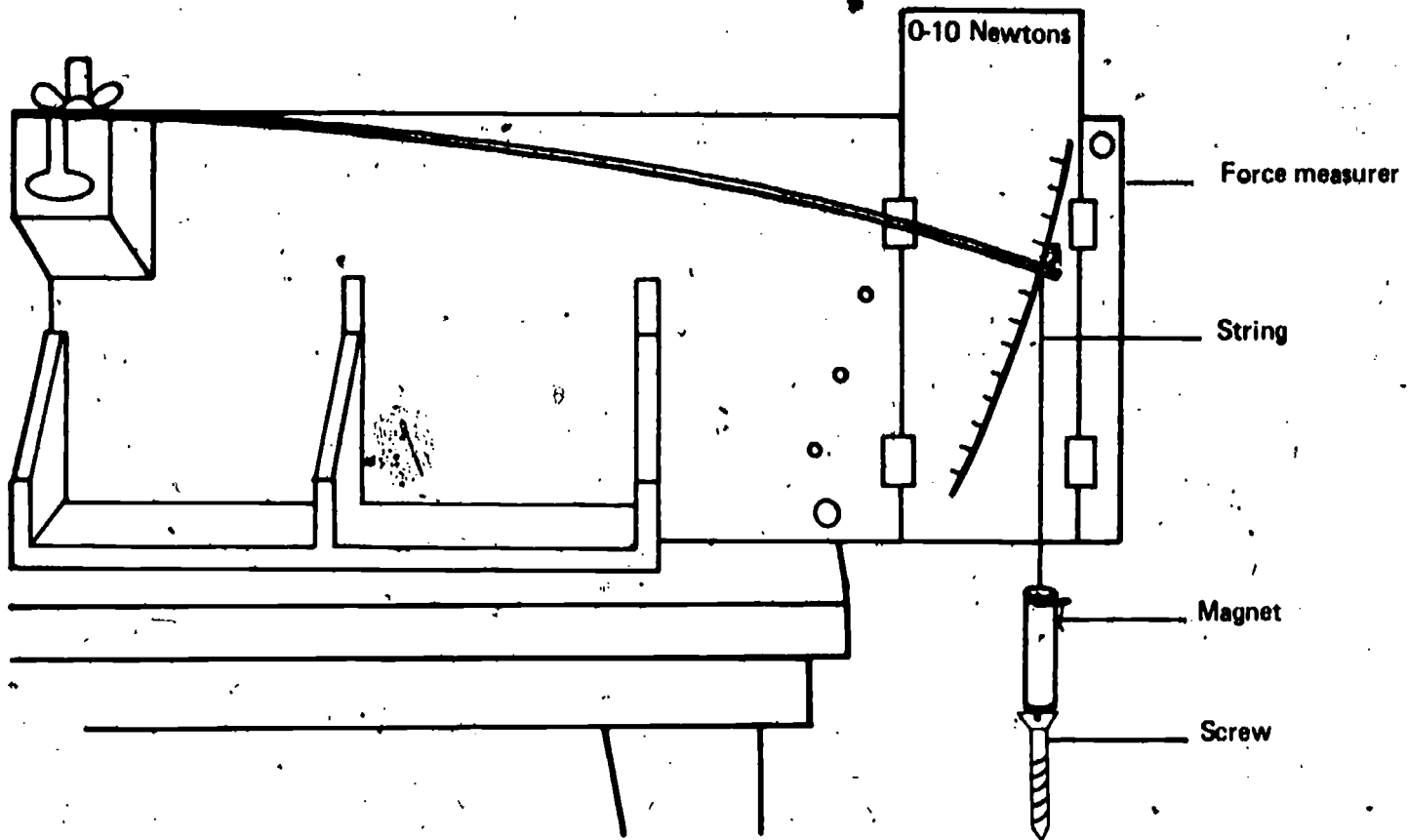

**02-Core-22B**

List the letters of the situations described below in which there is a force acting in addition to gravity and friction.

- a. A force measurer lifted from a desk
- b. A rock smashing through a window
- c. Two carts hitting head-on
- d. A motor sitting on a shelf
- e. A bus parked in a garage

**02-Core-23B**

If an object is to be used as a standard unit of measurement, name four things which should be true about it.

Arnold was given two old and uncalibrated spring scales, A and B. He calibrated each spring scale two times. The two drawings below show the results of his calibrations of each scale. Arnold must use one of these two scales in an experiment.

1. Which spring scale should he use?
2. Why?

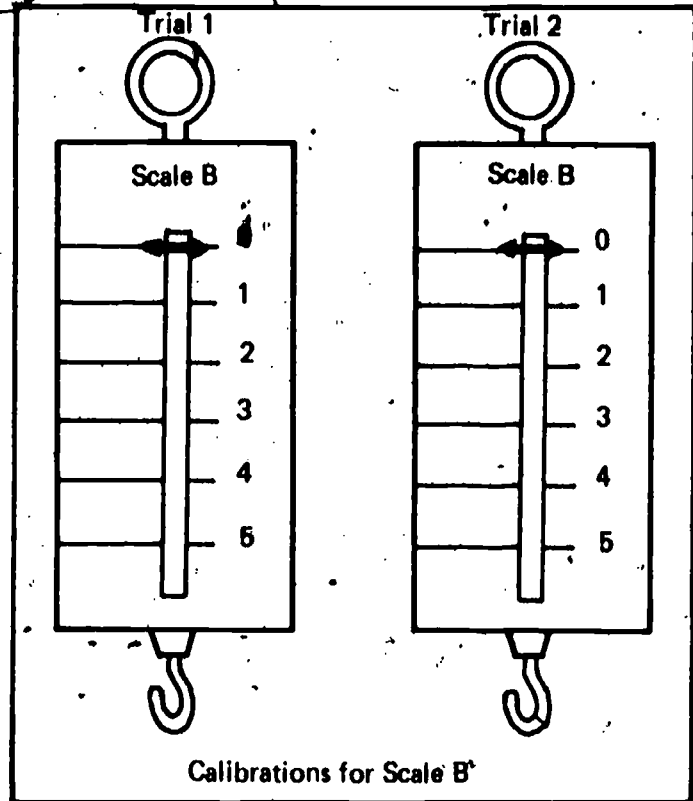
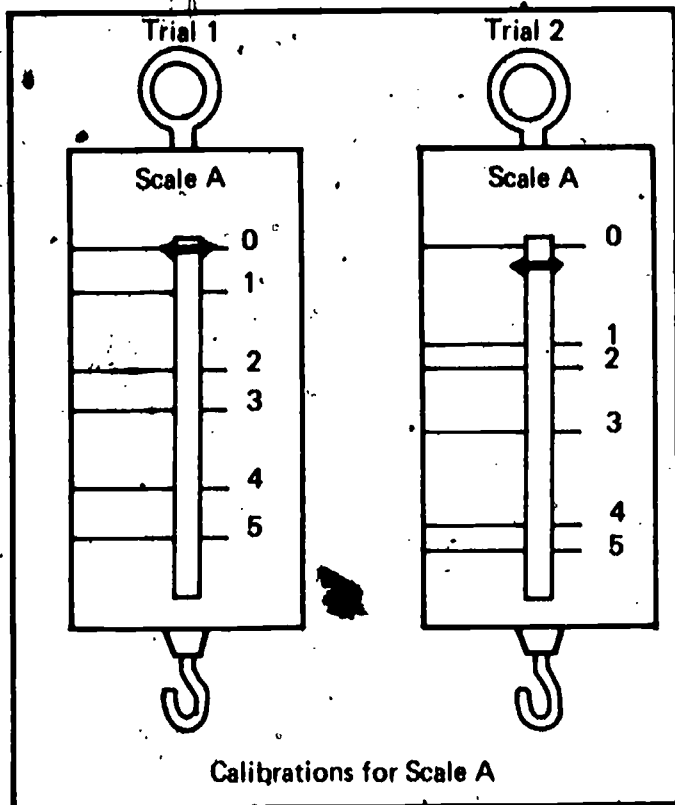

In this course, you often make several measurements which you are then asked to multiply and divide. Suppose you were to use the scale below.

02-Exc 06-1B

1. Would it be easiest to report, multiply, and divide the measurements if the units on the scale were divided into 9, into 10, or into 11 subunits?
2. Why?





02-Exc 06-2B

1. Which of the scales below would allow you to make the most accurate measurement from A to B?
2. Why?



02-Exc 06-3B

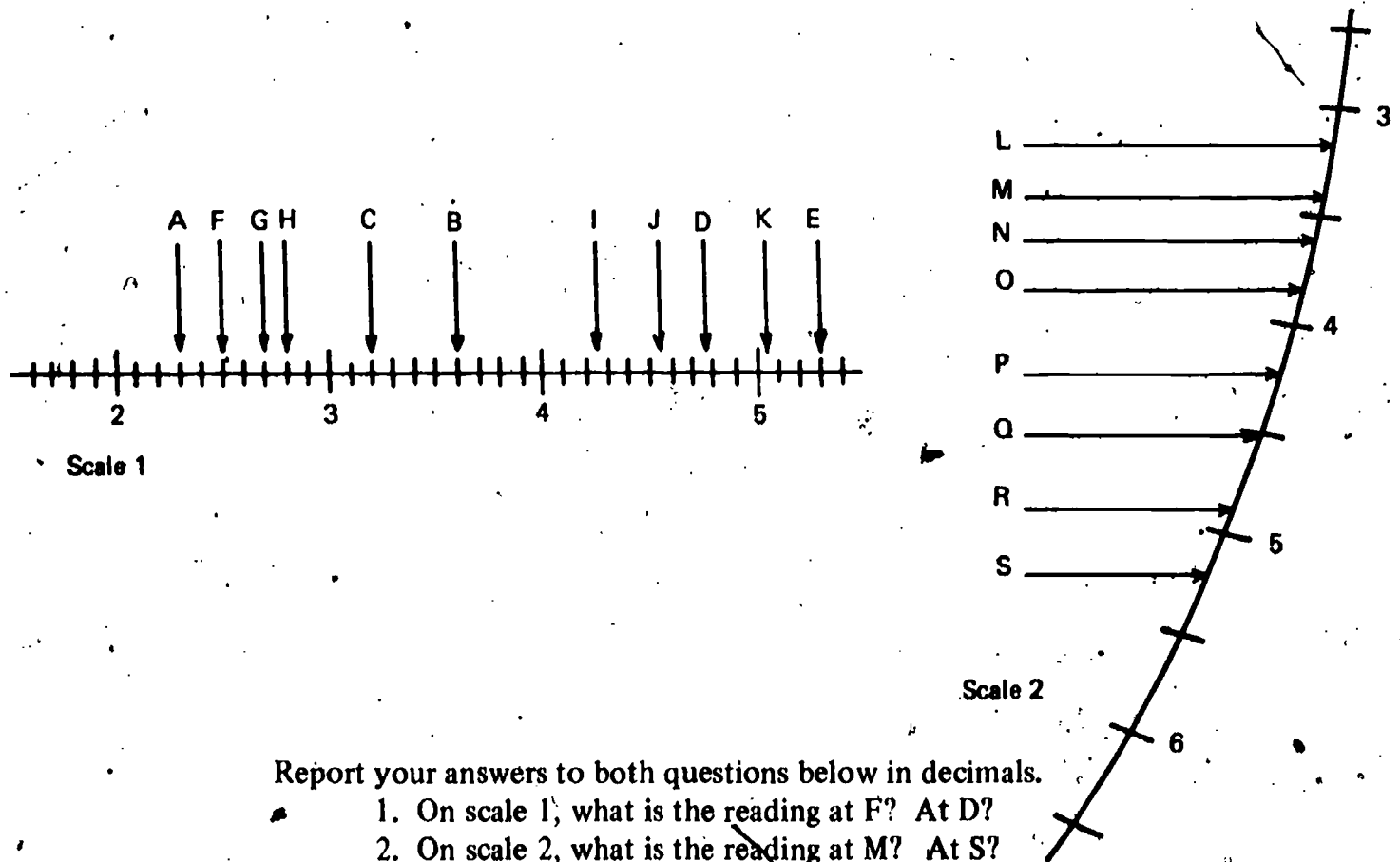

- Report your answers to both questions below in decimals.
1. On scale 1, what is the reading at F? At D?
  2. On scale 2, what is the reading at M? At S?

02-Exc 07-1B

- Write the letter of the best answer. When the size of a unit of measurement such as the meter was first determined, it was
- a. set by a group of men who agreed on its size.
  - b. taken from a list of standards passed down through the years.
  - c. naturally set by something in nature.
  - d. taken from the experiences of people.

The *cubit* is a unit of length based on the distance from a man's wrist to his elbow.  
The *palm* is a unit of length based on the width of man's hand.

02-Exc 07-2B

1. Why aren't measurement units such as the cubit and palm used very much today?
2. Why are standard units such as the meter and the gram used instead?

The brightness of a lighted bulb was measured with a light meter at several distances from the bulb. The data are graphed as shown below. Notice that the light brightness decreases as the distance increases.

02-Exc 08-1B

Compare the change in brightness between the distances 1 foot and 2 feet with the change between 4 feet and 8 feet. Choose the words which correctly complete the following two sentences.

1. When the bulb and meter are close together, a small change in distance produces a (large)(small) change in brightness.
2. When the meter and bulb are far apart, a large change in distance produces a (large)(small) change in brightness.

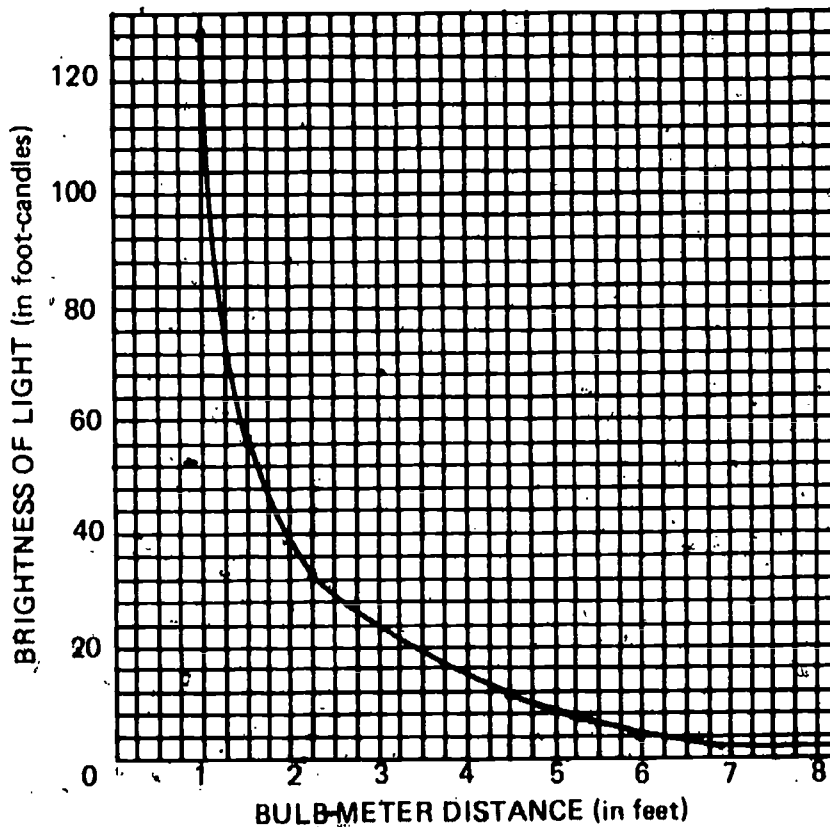

How can you lift a crate from the floor to a truck with the least amount of work being done on the crate? Select the best answer below.

03-Core-1B

- a. Any way you do it, the work on the crate is the same.
- b. Lift it with your hands.
- c. Push it up an inclined plane.
- d. Use a pulley and a rope.

Measure the distance between each of the three pairs of points, and report your answers in meters.

03-Core-2B

1. B to C
2. D to E
3. A to E

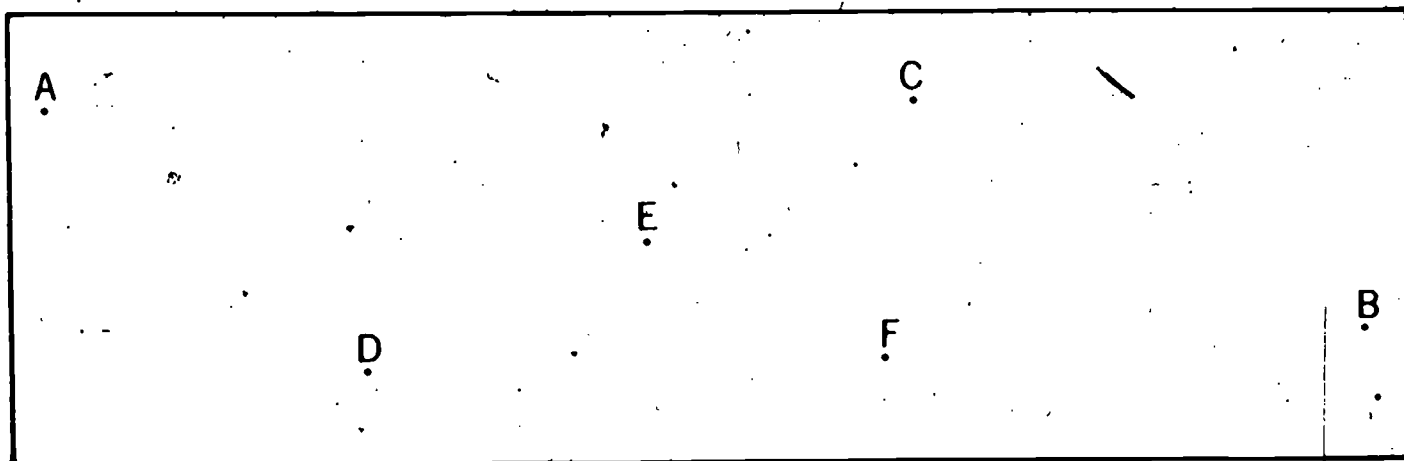

In each of the following cases, make the changes asked for.

03-Core-3B

1. 3.8 m = \_\_\_\_\_ cm
2. 0.9 m = \_\_\_\_\_ cm
3. 75 cm = \_\_\_\_\_ m
4. 8 cm = \_\_\_\_\_ m

Name the metric unit in which work is measured in ISCS.

03-Core-4B

Find out how much work is done when you lift a spinning top from the floor to your desk top. Get the equipment you need to do this. Record your measurements in newtons and meters and record the answer in the correct units.

03-Core-5B

An operational definition for *work* is \_\_\_\_\_.

03-Core-6B

Complete the sentence below.

03-Core-7B

George lifted the box from the floor and put it on the table. His ISCS classmates said he was doing \_\_\_\_\_ on the box.

03-Core-8B

A force measurer was used to pull a half-kilogram mass across the floor. What measurements below would you use to measure the work done on the half-kilogram mass? Choose as many as you need. Do not calculate the work done.

- a. The mass moved for 60 seconds.
- b. The mass moved 160 cm.
- c. The force measurer scale showed 7 newtons of force.
- d. The speed of the mass was 2 cm per second.

03-Core-9B

Match the terms *system*, *subsystem*, and *component* with their definitions. Write the number of the term and the letter of the matching definition on your answer sheet.

Terms

- 1. System
- 2. Subsystem
- 3. Component (of a system)

Definitions

- a. An object that is part of a system
- b. A person who fights another
- c. A group of objects that interact with each other
- d. A group of objects that interact directly within a system
- e. A group of objects, such as a hat, a book, a feather, and a clod of dirt

03-Core-10B

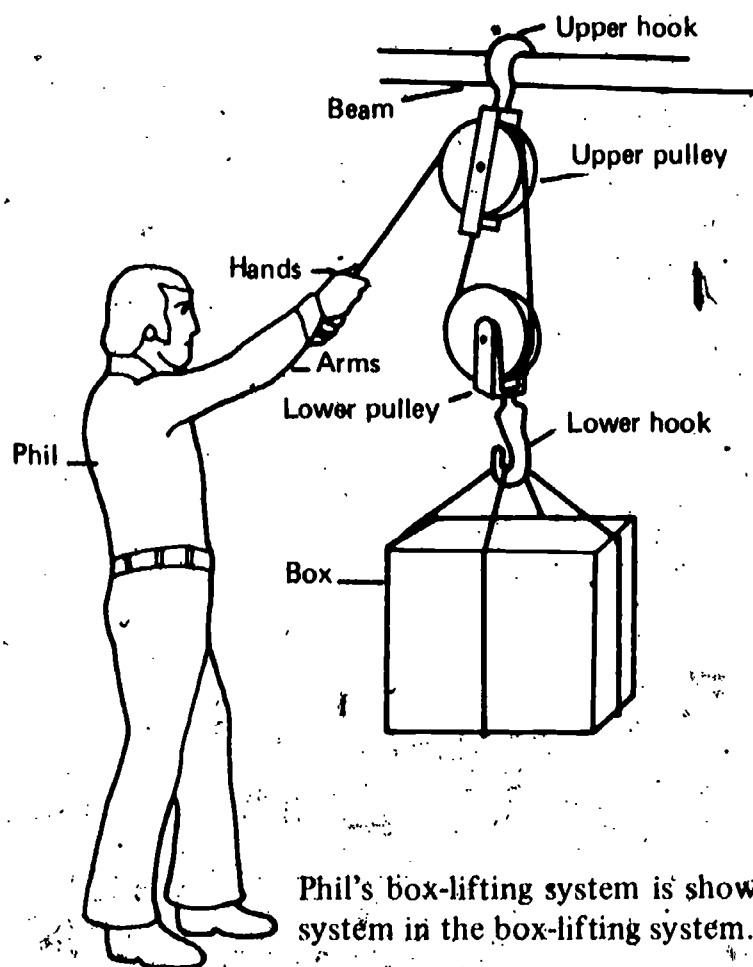

Phil's box-lifting system is shown. List four labeled components which form a subsystem in the box-lifting system.

Study the diagrams below.

03-Core-11B

1. List the letter of each diagram which shows a single system.
2. Explain why any diagrams you chose represent systems.

Diagram a

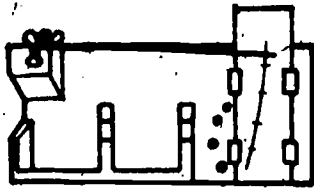

Diagram b

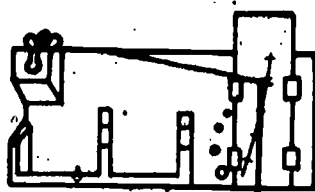
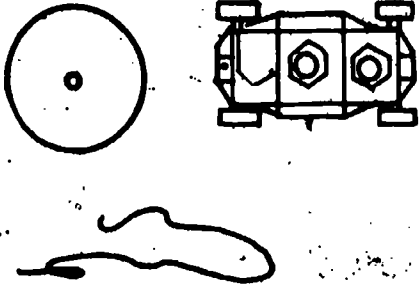
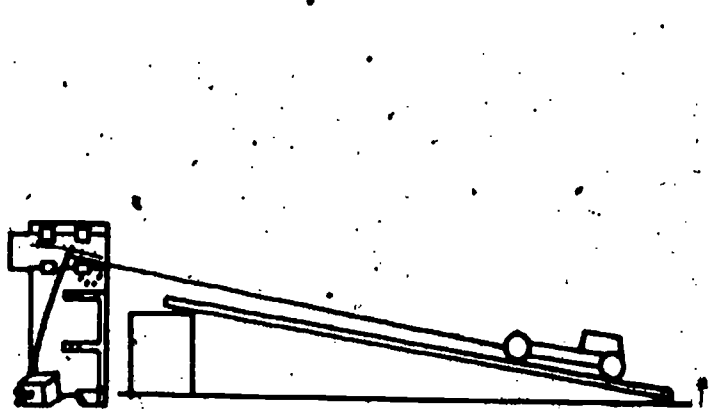

Diagram c



Study the diagram of the electric drill.

03-Core-12B

1. List any of the sets of components listed below which can be considered a subsystem.
2. Explain why you selected the sets you did.

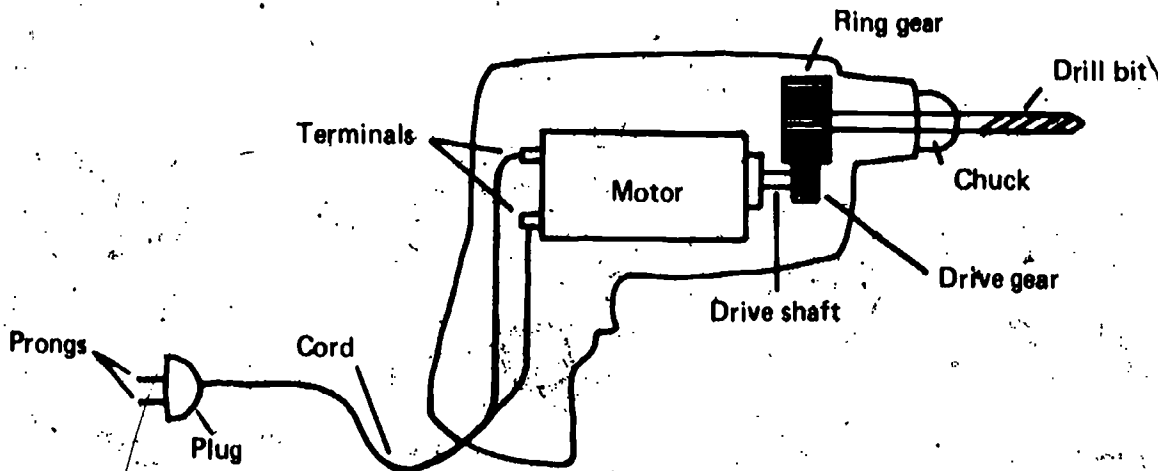

Components

- a. prongs, plug, cord
- b. prongs
- c. motor, drive shaft, drive gear
- d. terminals, plug, drive gear
- e. prongs, cord, drive shaft

Select the phrases which describe the relationship between work and systems. A system can

03-Core-13B

- a. have equal input work and output work.
- b. transfer input work.
- c. have higher output work than input work.
- d. use input work to do useful work.

03-Core-14B

Look at the diagram below. The farmer (B) wants to lift a bale of cotton (C). To move the cotton, he puts a board (A) over a sawhorse (D) and places one end of the board under the cotton. He then pushes down on the other end of the board and lifts the cotton.

1. What is the letter of the input component?
2. What is the letter of the output component?



03-Core-15B

In the diagram, consider the ball (A), the ruler (B), the table edge (C), and the  $\frac{1}{2}$  kg mass (D) to be a system. After the appropriate number, write the letter that identifies the source of the input work in the system and the letter that identifies the object on which the output work is done.

1. The input work is done on the system by \_\_\_\_.
2. The output work done by the system is done on \_\_\_\_.

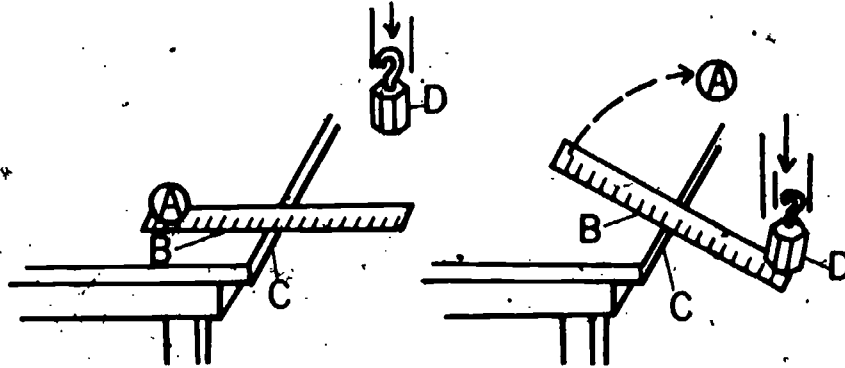

03-Core-16B

In the diagram below, think of the balance arm as a system. The force measurer shows a reading of 8 N and moved down 0.2 m. The 4 N weight moved up 0.35 m.

1. How much input work was done on the system?
2. How much output work was done by the system?

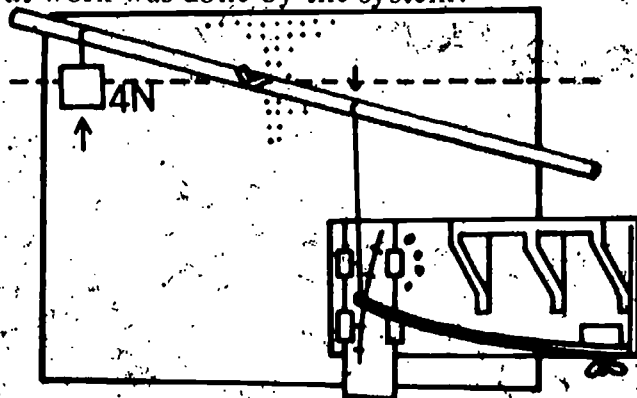

Jean checked the equal-arm balance system shown below. In doing that, she lifted the 4 N weight 0.3 meter. Her partner Sally asked her how much input work she had put into the system. What is the best answer Jean could have given?

03-Core-17B

- a. Exactly 1.2 N·m
- b. Just a little less than 1.2 N·m
- c. It is impossible to say, since no force or distance measurements were made of the input work.
- d. Just a little bit more than 1.2 N·m

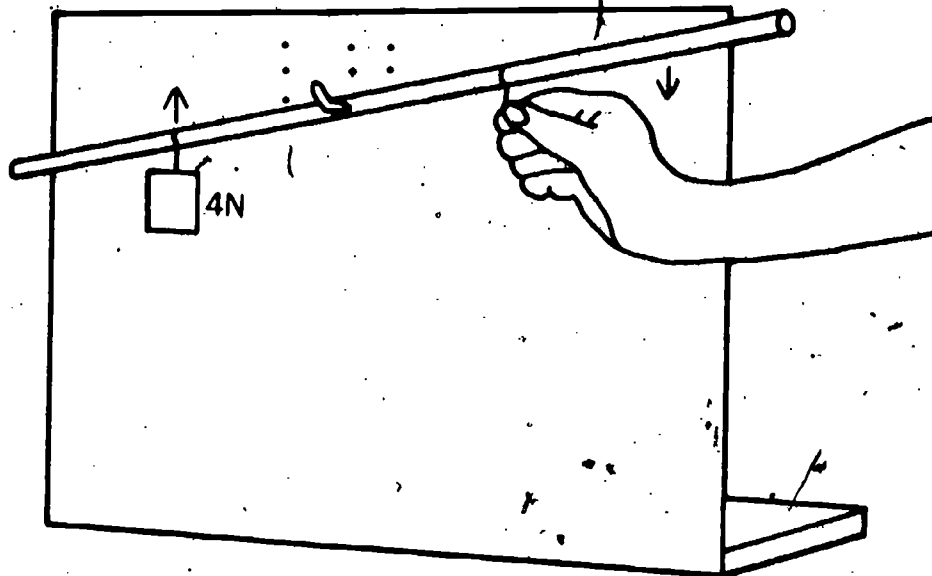

Find the average of each of the following two sets of numbers. Show your work.

03-Core-18B

- 1. 1.5, 3.5, and 2.4
- 2. 1.5, 2.6, and 3.8

Rene counted the turns of a phonograph turntable for one minute several times. Her data from several trials are recorded in the table below. Why is the average of 78 turns probably closer to the actual number of turns per minute than the individual figures for the six trials?

03-Core-19B

Trial	Turns Per Minute
1	79
2	80
3	76
4	79
5	77
6	77
Average	78

**03-Core-20B**

Four students determined the weight of a jar of sodium sulfate. Each student weighed the jar two times. Their data are shown in the chart below.

Student	Trial 1 (in N)	Trial 2 (in N)
Bill	4.801	4.798
Ann	4.803	4.802
Art	4.797	4.799
Dick	4.796	4.803

Why shouldn't the students expect to get the same answer each time?

**03-Core-21B**

Get from your teacher either a copy of the graph below or grid paper. (On grid paper, copy the graph below, label the axes, plot the points, and draw the line.) Using the graph, find the mass in grams of the following.

1. 11 sinkers
2. 3 sinkers
3. 7 sinkers
4. 5 sinkers

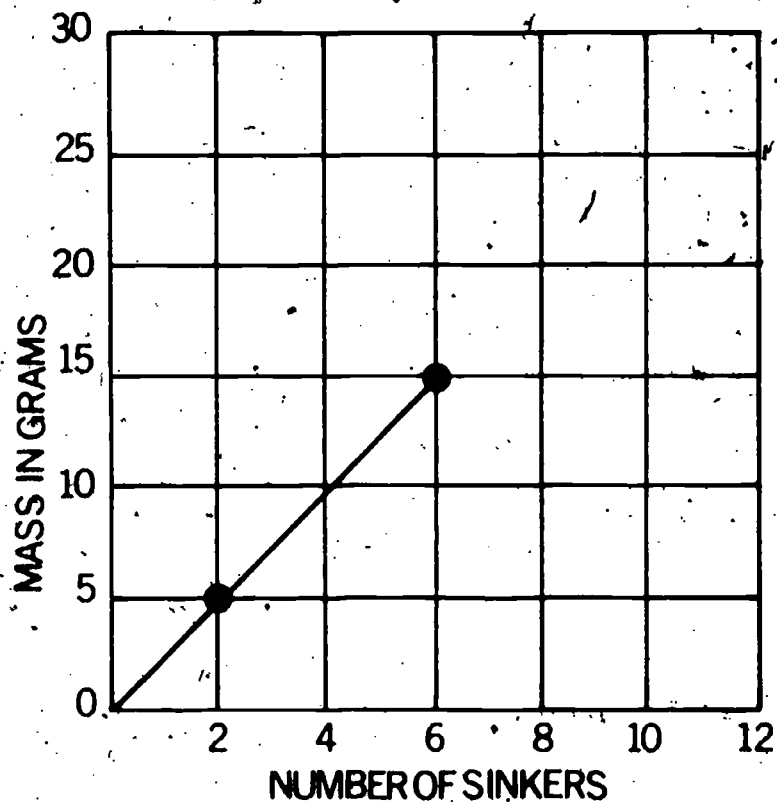
**03-Core-22B**

Bill attached his force measurer to a chalkboard eraser and then pulled the eraser across his table. The force measurer reading as the eraser moved along was 0.3 newtons. What is the name of the force he was measuring?

**03-Core-23B**

Explain why the work put into a system has to be greater than the output work desired.



When you rub sandpaper on a board, the sandpaper gets hot. What force causes the sandpaper to get hot?

03-Core-24B

Think of an empty box being dragged across a concrete drive. What would happen to the amount of friction if two bricks were placed in the box?

03-Core-25B

Mr. Jenkins wanted to find out what kind of gasoline was best. He also wanted to know which of his four cars went the farthest on a gallon of gasoline. He put a different kind of gasoline in each car. He then drove each of the cars and checked his mileage. What is wrong with Mr. Jenkins's experiment?

03-Core-26B

Joan did a study of noise. She dropped a skate wheel and a sinker from her desk top onto a carpeted floor.

03-Core-27B

1. Name a variable that is unchanged in both cases.
2. Name a variable that changes in the two cases.

A toothpaste manufacturer wants to know which of three chemicals will best destroy the bacteria which cause tooth decay.

03-Core-28B

1. What variable should be purposely varied in his experiment?
2. After the manufacturer has made the changes proposed in part 1, what variable does he study the changes in?

A racing car owner wants to know which of three kinds of engine oil will allow his car engine to make the most revolutions per minute. Naturally he will make all the tests on his own engine. Name two other factors he should keep unchanged if his trials are to be useful.

03-Core-29B

In the pulley arrangement shown in the diagram below, the mass and the pulley together weigh 20 N and will be lifted 20 cm. Read the sentences which follow. Select the one quantity in parentheses which best completes each sentence, and record your answers.

03-Exc 9-1B

1. To raise the mass and pulley 20 cm, the force would have to move (10, 20, 40) cm.
2. The amount of force required to raise the combined weight of 20 N of the mass and the pulley by pulling on the rope would be about (10, 20, 40) newtons.

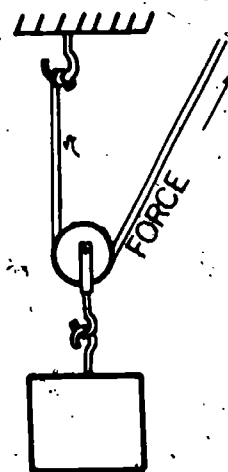

**03-Exc 10-1B**

In Excursion 10, you investigated the relation of input work to output work using three different pulley systems.

1. How does the input work compare to output work in movable pulley systems?
2. Why would you use movable pulleys to lift objects?

**03-Exc 11-1B**

The piano movers tried to use a ten-foot ramp, placed over the front steps of a house, to move a piano into the house. They couldn't push the piano up the ramp.

1. If the men replaced the ramp with a strong twenty-foot ramp, would the force required to push the piano up it be decreased, increased, or not changed?
2. Why is this the case when the longer ramp is used?

**03-Exc 12-1B**

Mrs. Williams holds a seesaw while Harold, who weighs 400 N, climbs on the right end 3 meters from the pivot. After his sister Lela, who weighs 350 N, gets on the other end at 4 meters, Mrs. Williams lets go.

1. Will the greater moment then cause the seesaw to turn clockwise or counterclockwise?
2. What is the amount of difference in the moments?

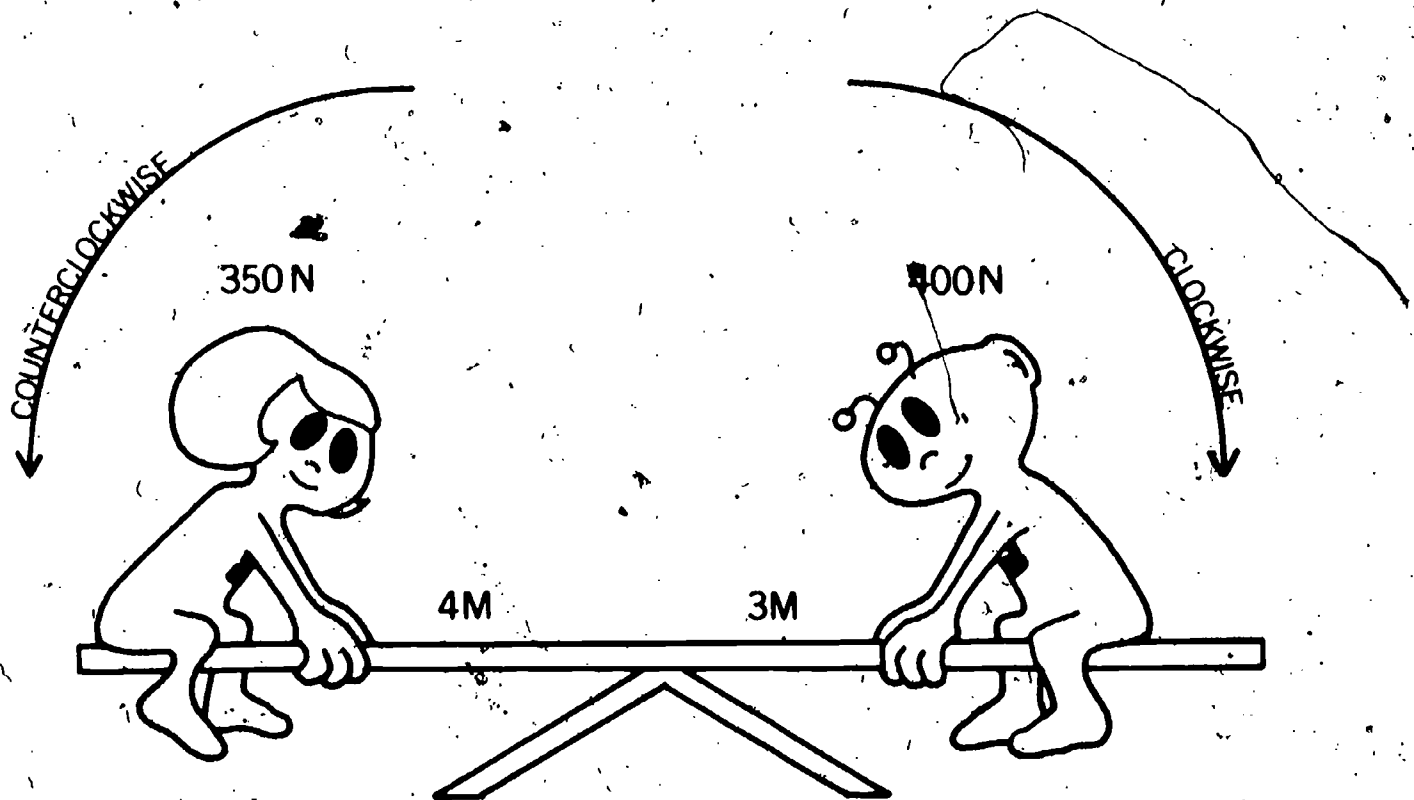
**03-Exc 13-1B**

Find the average to one decimal place for each set of numbers. Show your work.

1.  $8\frac{7}{8}$ ,  $7\frac{1}{2}$ ,  $7\frac{3}{4}$
2.  $4\frac{1}{4}$ ,  $5\frac{1}{2}$ ,  $3\frac{3}{4}$

The wood block shown below is dragged three times over a table. Each time a different surface, A, B, or C, is on the table. Which statement below best describes the result? The force of friction

03-Exc 14-1B

- a. will be greater on surface B than on C because the weight on B is greater than on C.
- b. will be greatest on surface A because all the weight is on the smallest surface.
- c. will be the same on all surfaces because the total weight acting on each surface is the same in all three cases.
- d. will be the smallest on surface C because it has the greatest area.

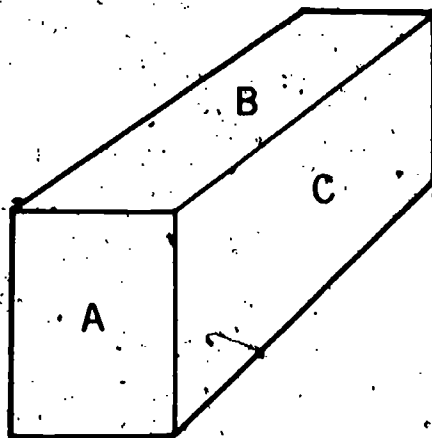

Imagine that a clockspring is wound or a trigger is cocked. What kind of energy is given to the clockspring or the trigger? Select the best answer below.

04-Core-1B

- potential energy
- motion energy
- gravitational energy
- heat energy

Loaded cannons, diesel fuel, and a rock on a ledge have potential energy. As *potential energy* is used in that sentence, what does it mean?

04-Core-2B

The spring is rolled up the track from 3 to 6 as the sinkers unwind from the shaft. Record the letters of any measurements you would use to calculate the change in the potential energy of the spring.

04-Core-3B

- Weight of the sinker in newtons
- Weight of the spring in newtons
- Height 2 in meters
- Height 5 above the floor in meters
- Distance 2 up the track in meters

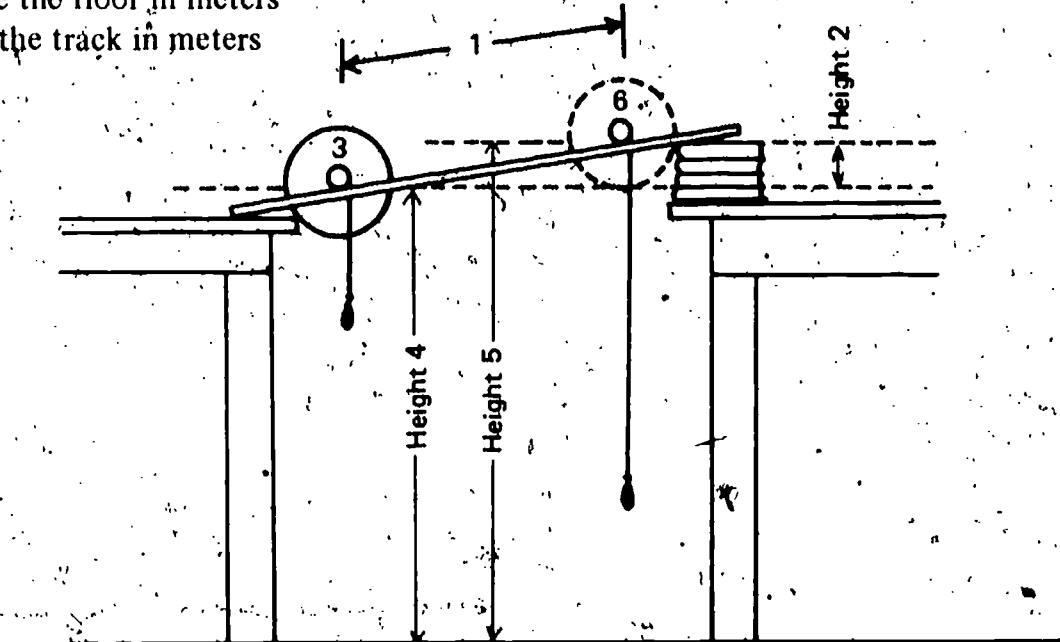

Three different hammers are used at the circus by some of the performers to drive tent stakes into the ground. The height at which the hammer is held before swinging is given for each one. Calculate the potential energy each hammer could supply to drive the stakes. Show your calculations and answers on your paper.

04-Core-4B

Performer	Weight of Hammer (in newtons)	Height above Stake (in meters)
1. Midget	4.5	0.6
2. Average Man	8.3	1.3
3. Giant	13.0	2.0

04-Core-5B

1. If Harold lifts a box off the ground to the top of a wall, does he give it energy?
2. If so, what kind of energy does he give it? If not, why doesn't he give it energy?

04-Core-6B

What is a unit in the metric system used in ISCS to report the gravitational potential energy of an object?

04-Core-7B

Your instructor has suspended an object, labeled 04-Core-7B, above the floor. Use your force measurer and meterstick to find its potential energy. Show your measurements and calculations.

04-Core-8B

Look at the diagram below. The motor lifts the weight when the wires are hooked from the battery.

1. Name the component doing the input work.
2. Name the component receiving the output work.

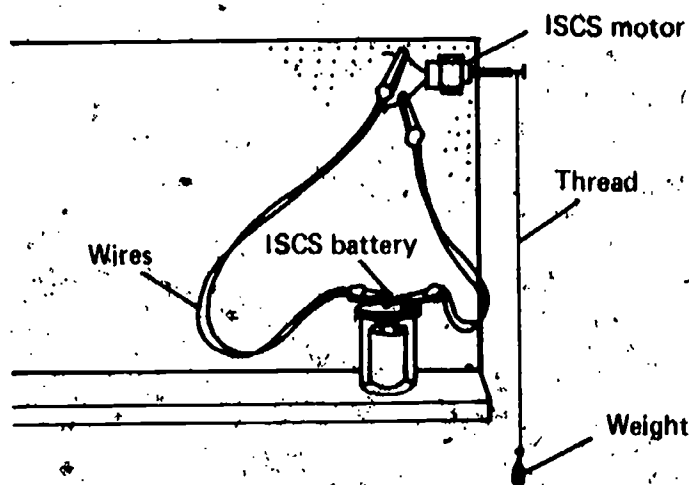

04-Core-9B

What does *input work* mean?

04-Core-10B

Select the phrase that completes the following sentence. The object that does work on something else in a system is called the

- a. output work.
- b. input work.
- c. energy receiver.
- d. energy supplier.

04-Core-11B

Select the phrase that completes the following sentence. The object that has work done on it by something else in a system is called the

- a. energy supplier.
- b. output work.
- c. input work.
- d. energy receiver.

Tell a way in which you can decide whether or not an object has motion energy. You may use an example if you wish.

04-Core-12B

Set in the roller bearing blocks, you have a 4-disk spinigig with a string wrapped around its axle. Attached to the string is one sinker that can fall 1 meter and cause the spinigig to spin. What effect would increasing the number of sinkers have on the spinigig's speed of rotation?

04-Core-13B

Suppose your spinigig turns 15 times in 30 seconds. What is its speed in turns per second? Show your calculations on your paper.

04-Core-14B

What does the curved line on the graph tell you about the birthrate of bears in the game preserve? (Hint: Compare the change in the birthrate between the 5th and 6th years with the change between the 1st and 2nd years.)

04-Core-15B

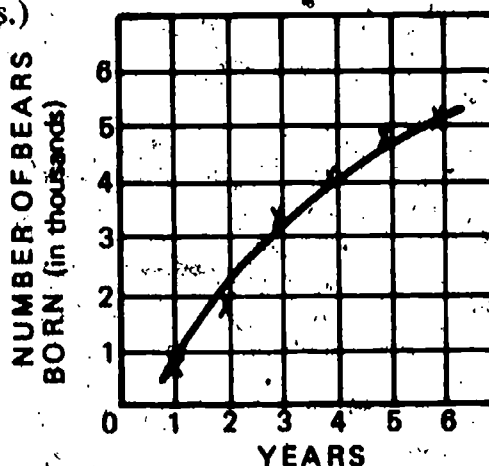

If you are asked to report the speed of a spinning object such as a spinigig, what unit do you use?

04-Core-16B

Get some graph paper, draw a pair of axes, and label them as shown below. Use your grid and the table below to plot rocket speed against fuel used. Draw a best-fit line for the plotted points.

04-Core-17B

Rocket Speed Per Ml of Fuel

Speed (m/sec)	Fuel (ml/sec)
2	10
4	15
6	19
8	22
10	23
12	25
14	26
16	27
18	27

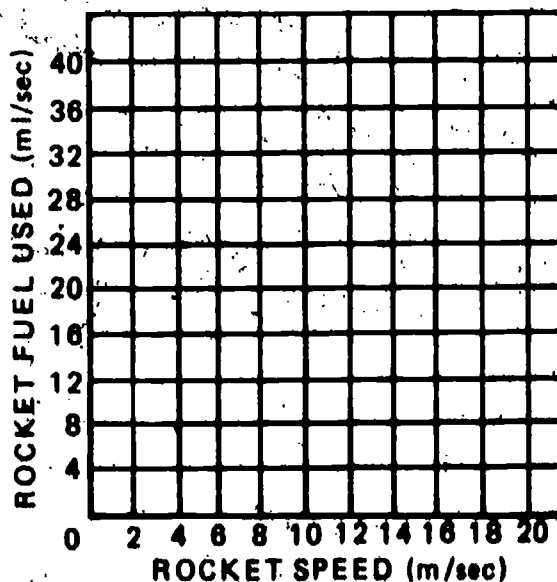

04-Core-18B

What two things does the best-fit curved line on the grid below tell you about the pull of gravity on the spaceship as it gets farther from the earth?

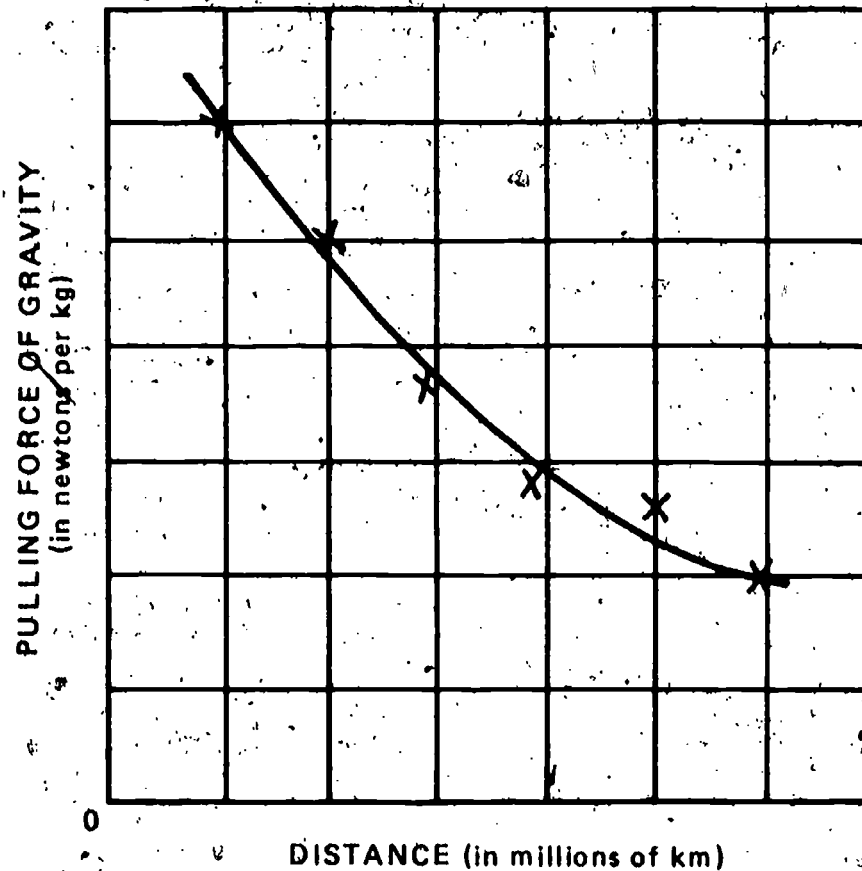

04-Core-19B

A spinigig with 1 disk and a string wrapped around its axle is set into the roller skate wheels and placed on the track. Attached to the string are 4 sinkers that can fall two meters and cause the spinigig to spin. What effect would increasing the number of disks on the spinigig have on its speed of rotation?

04-Core-20B

Define *mass*. (Hint: Consider how it is used in the following sentence.) The mass of the rubber ball was equal to the mass of the golf ball.

04-Core-21B

Delano picked up a chair and set it on a table. The chair gained potential energy. What kind of energy did Delano apply to the chair?

04-Core-22B

1. What kind of energy does an elevator have when it is held thirty feet above the ground floor by a cable?
2. If the cable is cut and the elevator falls, its energy changes. What kind of energy is it changed to?
3. What force acts upon the elevator after the cable is cut to change the energy?

Look at the diagram below. A man uses a sledge hammer to drive a post into the ground. When the hammer is swung, it strikes the top of the post and pushes it into the ground.

04-Core-23B

1. Name the supplier of input energy to the system.
2. Name the receiver of output energy from the system.

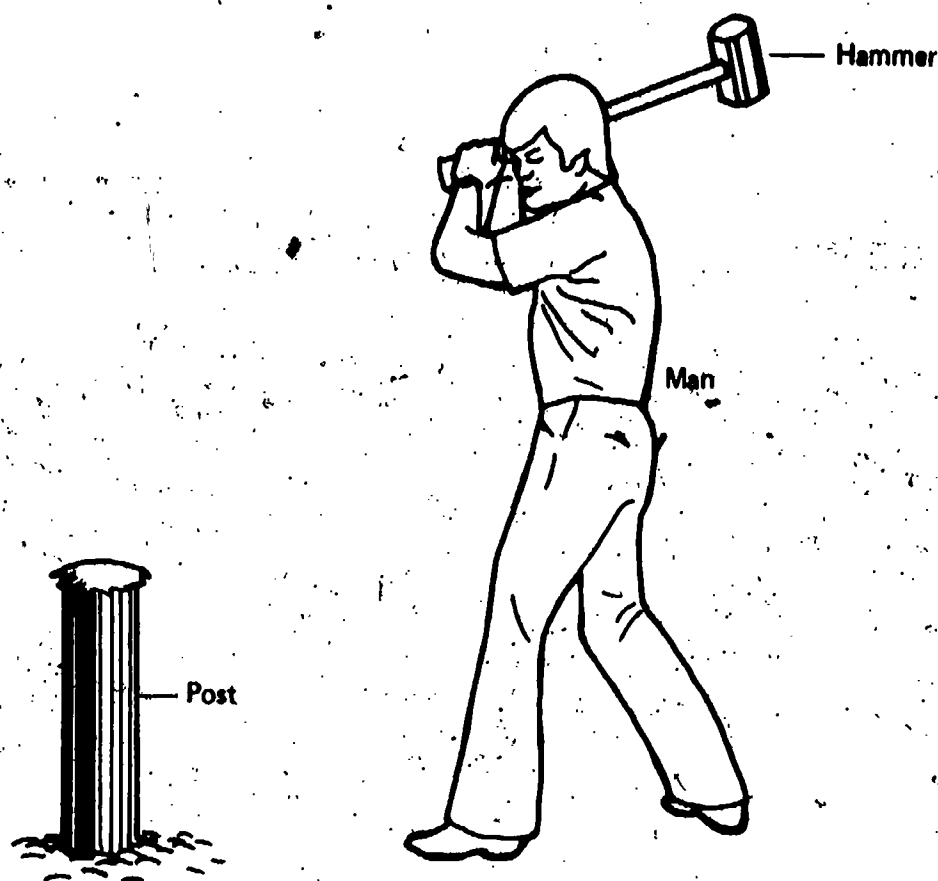

When a fist moves, it has energy. It can knock on a door. How could the energy of a moving fist be measured as it strikes the door?

04-Core-24B

The force required to slide a bale of straw on the ice is 8.4 newtons. Helen was skating on the ice. She fell and slid into the bale of straw. The bale moved 5 meters. How much motion energy did Helen have if it was all given to the bale of straw?

04-Core-25B



04-Core-26B

In the diagram below, arrows correctly show the direction in which five spinigigs are moving. However, some of the labels are incorrect. List the number of each of the incorrect labels.

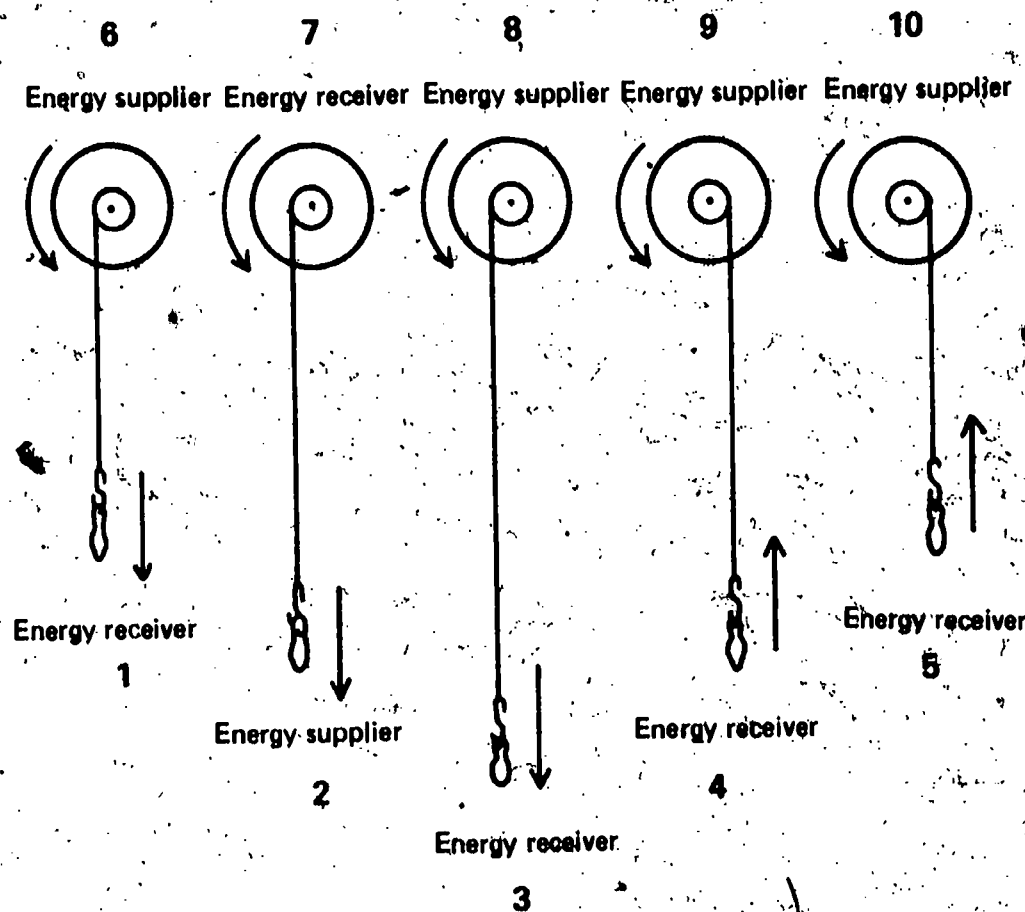

04-Exc 15-1B

Europa is a moon of the planet Jupiter. It is smaller than earth's moon. The force of gravity on a 1 kg mass on Europa is about 1.07 newtons. On earth, it is about 9.8 newtons.

1. If a bowling ball were taken from earth to Europa, would its mass change?
2. What would happen to its weight?
3. How did you know what answers to give?

04-Exc 15-2B

A golf club was taken to the moon by one of the astronauts.

1. Did the mass of the golf club change during the trip?
2. What have you learned about *mass* that supports your answer?

Answer both 1 and 2 below by selecting the letter that best completes the sentence in each case.

04-Exc 16-1B

1. Excursion 16, "Forerunners of Space Travel," tells how eleven men who lived from 400 B.C. to 1725 A.D. developed ideas about astronomy. One thing that all of these men did was

- contribute new ideas.
- look through telescopes to observe the stars and planets.
- study geography and mathematics.
- build rockets or spaceships.

2. Newton said, "If I have seen further than other men, it is because I have stood on the shoulders of giants." He meant that

- the falling apple caused him to see stars.
- he had the advantage of others' ideas and could improve and advance them.
- he was short himself but could see farther when someone held him up.
- Kepler's idea of planets in orbits could be explained by his own idea of the pull of gravity.

Each of the following four statements describes a relationship between the variables age and height. Beside the number of each statement, record the letter of the graph below which shows the same relationship.

04-Exc 17-1B

- As age increases, height decreases at a changing rate.
- As age increases, height decreases at a constant rate.
- As age increases, height increases at a constant rate.
- As age increases, height increases at a changing rate.

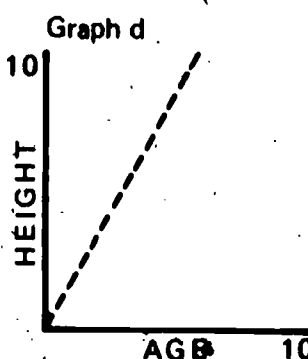
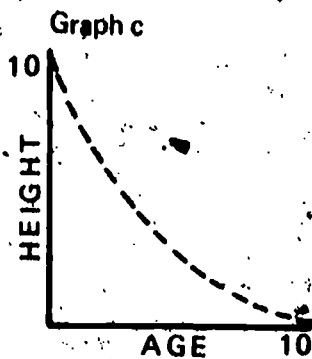
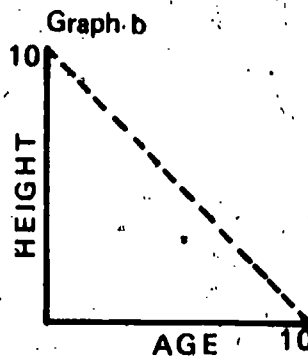
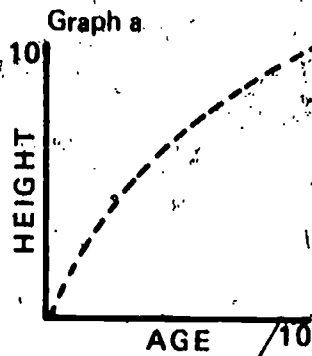

04-Exc 18-1B

After the number of each of the following four statements, match the letter of the graph that illustrates the relationship described in the statement. You may use the letter of a graph more than once.

1. When height increases at a constant rate, speed decreases at a constant rate.
2. When height increases at a constant rate, speed is not changed.
3. When height increases at a constant rate, speed increases at a constant rate.
4. When height decreases at a constant rate, speed increases at a constant rate.

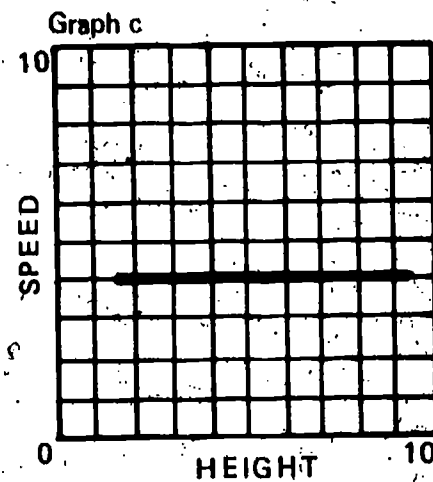
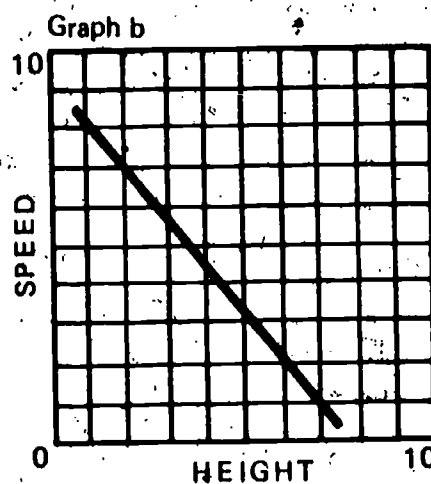
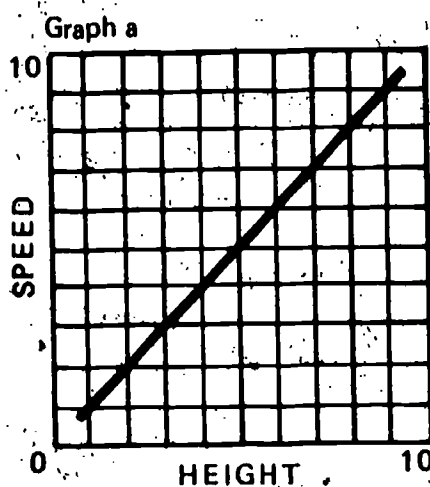

04-Exc 19-1B

Objects which fall move faster and faster as they are acted on by gravity. A ten-story building is on fire. People are dropping their possessions out the windows. Object A, which has a mass of 3 kg, is dropped from the fourth floor of the building. It has a speed of 7 meters per second when it nears the ground. Object B, whose mass is 15 kg, is dropped from the second floor and has a speed of 3 meters per second as it nears the ground. Use the formula  $KE = \frac{1}{2}mv^2$  to answer the following questions. Your answers will be in newton-meters.

1. Which of the two has the greater kinetic energy? How much more does it have? Show your calculations.
2. Which of the two would do more damage if it hit the top of a parked car?

When a spring has been stretched, what kind of energy does it have?

05-Core-1B

05-Core-2B

	Trial 1	Trial 2
Average of force of blade	7.2 N	8.5 N
Distance blade tip moved	0.044 m	0.017 m
Work done on cart	0.307 N·m	0.125 N·m

Sheila used her force measurer as the input work supplier to her water-clock cart. When she studied her data, she saw that in Trial 1 she had used a smaller force than in Trial 2. She then noticed that more work had been done on the cart using the smaller force. Could this be true? Explain your answer.

Ed bought a gun that shoots rubber-tipped darts. He noted that it took 0.5 newton of force to start to push the dart into the gun. The force had to be increased to 5.5 newtons to complete the task. He noted that a force was applied against the dart for 0.12 m. What was the potential energy of the spring when it was fully compressed?

05-Core-3B

Define *kinetic energy* with an operational definition.

05-Core-4B

How can you tell if a water-clock cart has kinetic energy?

05-Core-5B

How would you measure the amount of kinetic energy a moving automobile has?

05-Core-6B

William Tell pulled a bowstring through the five positions labeled on the diagram below. After holding the bowstring at E for a second, he released it.

05-Core-7B

1. Identify by letter the position at which the potential energy of the bowstring was the greatest.
2. Identify by letter the position at which the kinetic (motion) energy of the bowstring was the greatest.

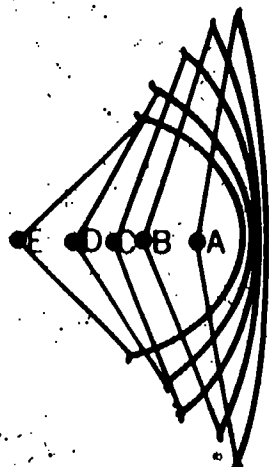

05-Core-8B

An object at L weighs 4.9 N. A second object at N weighs 2.4 N.

1. Which of the following states the direction of movement: L to M or N to M?
2. Which of the following correctly states the amount of force acting to produce the motion: 7.3 N, 2.5 N, or 11.8 N?

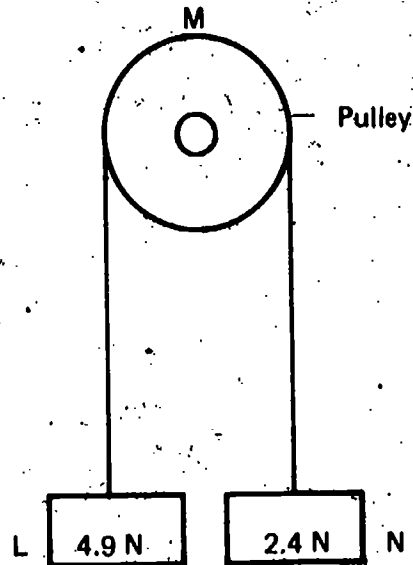

05-Core-9B

Look at the record below of the movement of a water-clock cart. This record was made by a moving cart which dropped a drop of water every two seconds.

1. List the letters between which the cart's speed is increasing.
2. List the letters between which the cart's speed is decreasing.
3. List the letters between which the cart's speed is constant.

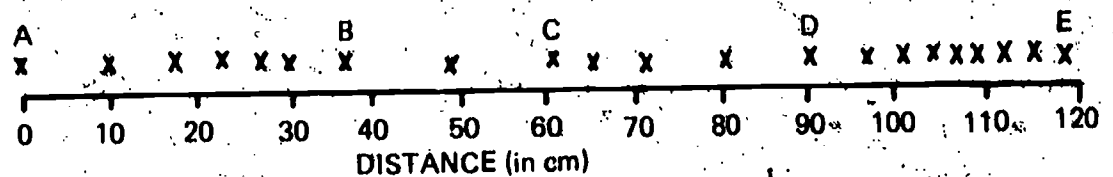

05-Core-10B

Neal set a marble at the top of an inclined plane and released it without pushing it. What force caused the marble to roll down the incline?

05-Core-11B

A Ping-Pong ball bounced once, then rolled on the floor. It gradually slowed down and stopped rolling. What force caused the Ping-Pong ball to slow down and stop?

05-Core-12B

A generator is an energy converter in which kinetic energy is changed to useful electrical energy. When the output electrical energy is measured, however, it is always less than the amount of input mechanical energy. What force causes this decrease?

1. Write the letter of the choice that completes the sentence best. When 84 newton-meters of input work is done by a horse on a treadmill, the treadmill might do

05-Core-13B

- a. 84 newton-meters of output work.
- b. 37 newton-meters of output work.
- c. 154 newton-meters of output work.

2. Write the letter of the reason for your choice.

- a. Because in a system input work is always greater than output work
- b. Because the horse doesn't waste any energy
- c. Because the treadmill saves work, as a machine does

Choose the correct word to complete the following sentence. As he took off, Craig Breedlove spun the wheels of his jet-powered car on the Bonneville Salt Flats. The wheel-spinning caused the temperature of the tires to (increase, decrease, stay the same).

05-Core-14B

Name six forms in which energy exists.

05-Core-15B

Think of the changes in energy that occur in the following situation. A box

05-Core-16B

1. is lifted from the floor,
2. reaches its maximum height of 2 m and stops,
3. falls, and
4. is about to strike the floor.

For each numbered step above, select two things from the table below – the letter (e, f, g, or h) of the phrase which describes the potential energy of the box at that moment and a letter (m, n, o, or p) which describes the kinetic energy of the box at the same moment.

Potential Energy	Kinetic Energy
e. gains potential energy	m. gains kinetic energy
f. loses potential energy	n. receives input of kinetic energy
g. lowest potential energy	o. no kinetic energy
h. greatest potential energy	p. greatest kinetic energy

If light is a form of energy, then it can do work. Describe a way that you tell if light energy is present in some way besides seeing the light or an object which the light illuminates. Also state what you would need to do to measure the amount or intensity of the light.

05-Core-17B

Jennifer says she knows that light is a form of energy because light can do work. She can prove it by naming two devices that do work when light shines on them. Name one of the instruments, and tell how it proves that light is a form of energy.

05-Core-18B

05-Core-19B

Get a palm glass, and tilt it until all the liquid is in one of the bulbs. Hold the full bulb gently in your hand, as shown in the picture below. Be sure the cross tube is below the bulbs and the empty bulb is higher. Choose the correct answer below. What causes the liquid to move toward the other bulb?

- a. Light energy
- b. Animal sense energy
- c. Pressure
- d. Heat energy

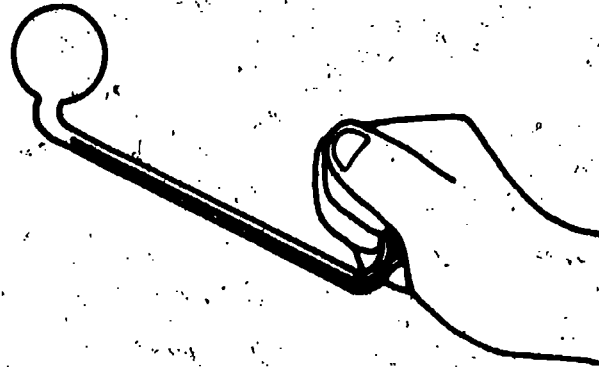

**CAUTION: HOLD GENTLY**

05-Core-20B

Give two examples which show that electrical energy can be changed into kinetic energy.

05-Core-21B

Read the following story. While working on Chapter 10, Richard put nails into holes 1 and 3 of the force measurer and pushed the cart back until the blade touched the nail in hole 3. (You may look at a force measurer if you wish.) Then he observed the following things.

1. The blade was bent back.
  2. The blade snapped forward (from hole 3 to hole 1).
  3. The cart lifted the sinkers.
- Penny stopped the cart, but it slipped.
4. The sinkers began to fall, and the cart sped backwards.
  5. The blade bent back when the cart hit it.
  6. The sinkers lay flat on the floor.

Beside the number of each step, write P-K if potential energy is being changed to kinetic energy and K-P if kinetic energy is being changed to potential energy. Write N if there is no change in the form of energy.

05-Core-22B

Write the letters of all the statements which are true about energy.

- a. Energy can be measured by speed times force.
- b. Energy can be changed from one form to another.
- c. Energy can be transferred from one system to another.
- d. Energy can exist in more than one form.
- e. Energy can be identified as having density.

Examine the diagram below.

05-Core-23B

1. State the form or forms of input energy shown in the diagram.
2. State the form or forms of output energy shown in the diagram.

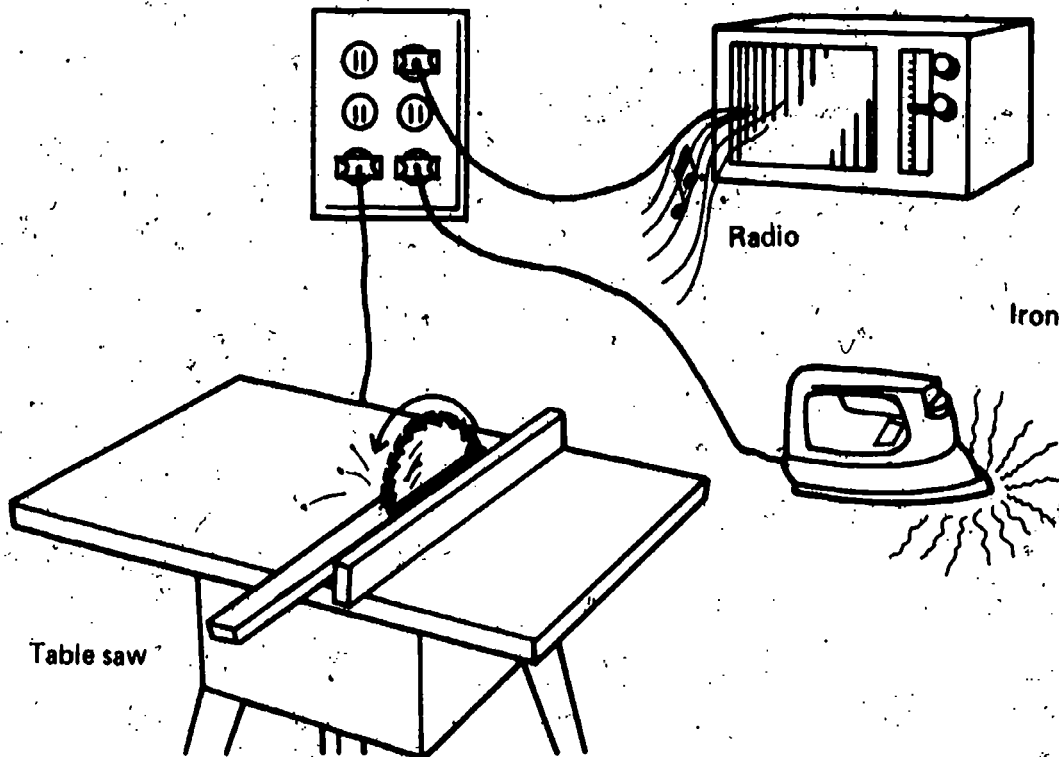

In your home, you use many things which convert energy from one form into another.

05-Core-24B

1. List three energy converters found in your home.
2. Give the form of the input energy and the output energy for each. For example, light bulb: input energy — electrical; output energy — heat and light.

A water clock drips 39 drops in 19 seconds. The water-clock cart leaves a trail of water drops 4 cm apart. What is the speed of the cart in centimeters per second?

05-Exc 20-1B

Pierre, an ISCS student, watched a beetle walking around the circumference of a spinning disk which hung in the rack. He timed one of the trips around and found it took the beetle 6 seconds. How far did the beetle walk? At what speed was it moving? You may get a spinning, 50 cm string, and a meterstick to make whatever measurements you need. Show your measurements and your calculations. Report your answer in centimeters per second.

05-Exc 21-1B

The following things are known about a spaceship.

05-Exc 22-1B

- a. It has a thrust of 1,500,000 lbs.
- b. It has a mass of 12,000 mass units.
- c. It can accelerate in flight with an additional thrust of 850,000 lbs.
- d. It passes the planet Mars at a speed of 22,700 miles per hour.

Write the letter of each variable needed to calculate the spaceship's momentum.



Assume that the equipment shown in the diagram below is all in good working order.

06-Core-1B

1. Will the bell ring?
2. Why do you believe the bell will or will not ring?

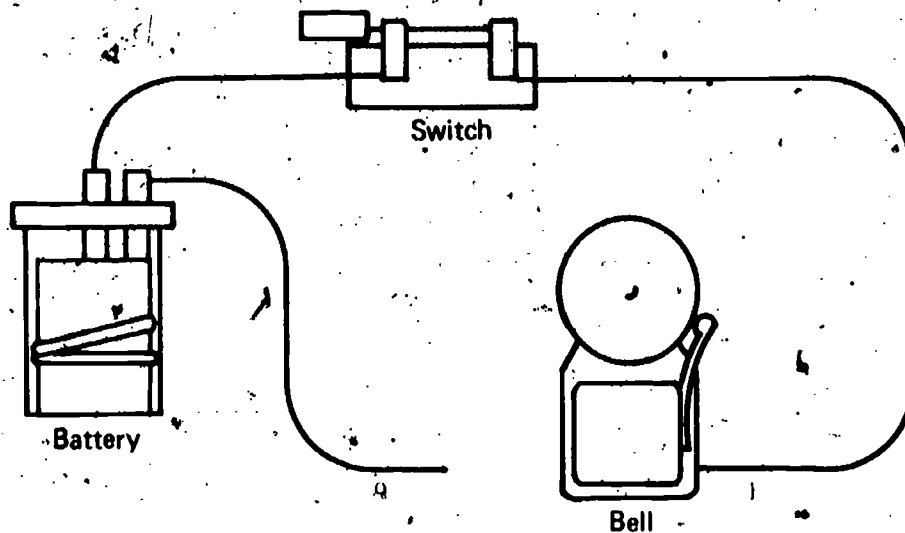

Get the bottle of blue solution labeled 06-Core-2. Your activities in Chapter 12 include using this solution to coat the carbon rod with a reddish-brown substance. Which material in this solution contributed the coating on the rod?

06-Core-2B

- a. copper
- b. water
- c. oxygen
- d. sulfate

The carbon rod in box 06-Core-3 is covered with a material produced during the activities connected with Chapter 12. What is the coating made of?

06-Core-3B

A rechargeable battery is connected to an electric battery charger. Select the letter of the sentence below which describes the energy conversion within the battery during the charging.

06-Core-4B

- a. Electrical energy is changed into chemical energy.
- b. Chemical energy is changed into kinetic energy.
- c. Electrical energy is changed into kinetic energy.
- d. Chemical energy is changed into electrical energy.

Name the form of energy that is stored in a battery.

06-Core-5B

1. What happens inside a rechargeable battery in a portable TV set during charging?
2. When it discharges to the TV set, what happens inside the battery?

06-Core-6B

Leonard has a battery, 2 motors, and 3 test leads. What must he do to make a complete electrical circuit? You may use a diagram as part of your answer.

06-Core-7B

06-Core-8B

Go get 1 charged flashlight battery, 2 bulbs and sockets, and 3 test leads. Using these materials, connect the two bulbs in a series circuit. Show your teacher what you have done.

06-Core-9B

Draw a diagram showing a switch, a battery, a light bulb, and two motors connected in series.

06-Core-10B

For each of the following statements, state whether the electrical devices mentioned are wired in *parallel* or in *series* with each other. Write *series* or *parallel* on your answer sheet next to the number for each statement.

1. A lamp has two light bulbs in it. One bulb is 60 watts. The other bulb is 100 watts. The lamp is turned on, and the 60-watt bulb burns out. But the 100-watt bulb still stays on. How are the two bulbs in the lamp wired?
2. When the switch on a lamp is turned off, the light goes out. When the switch is turned on, the bulb burns brightly. How are the switch on the lamp and the bulb wired?
3. Suppose you wish to roast meat in an electric oven. You set the electric timer on your oven for two hours. At the end of two hours, the timer rings and shuts off. The oven also shuts off. How are the timer and the oven wired?

06-Core-11B

Draw a diagram which shows a battery, a bulb, and two motors wired in parallel.

06-Core-12B

Get the following: 1 charged "D" size battery, 3 bulbs and sockets, and 6 test leads. Using these materials, connect the three bulbs in a parallel circuit. Show your teacher what you have done.

06-Core-13B

Look at the circuit diagramed below. Suppose you added an additional motor in series with the circuit. How would this affect the amount of electrical energy the other motor and the bulbs receive?

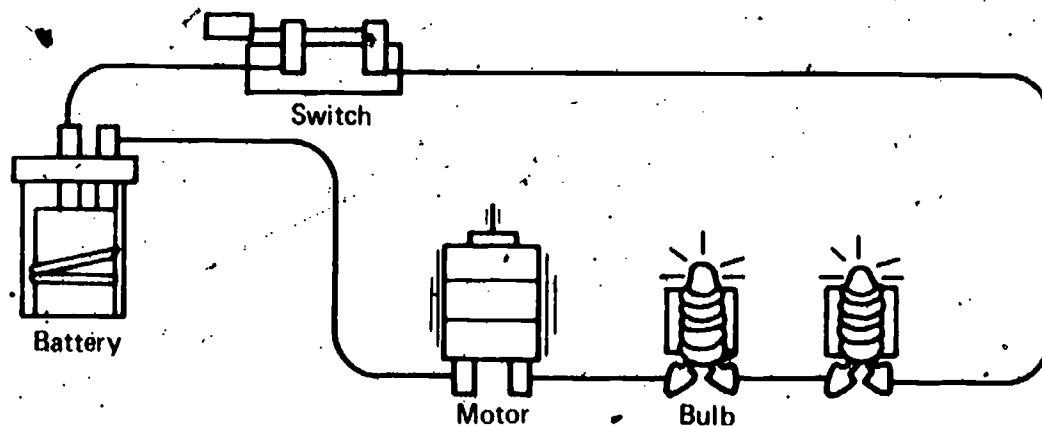

The amount of current flowing in the circuit diagramed below can be reduced in several ways. State one way in which the current can be reduced but not stopped.

06-Core-14B

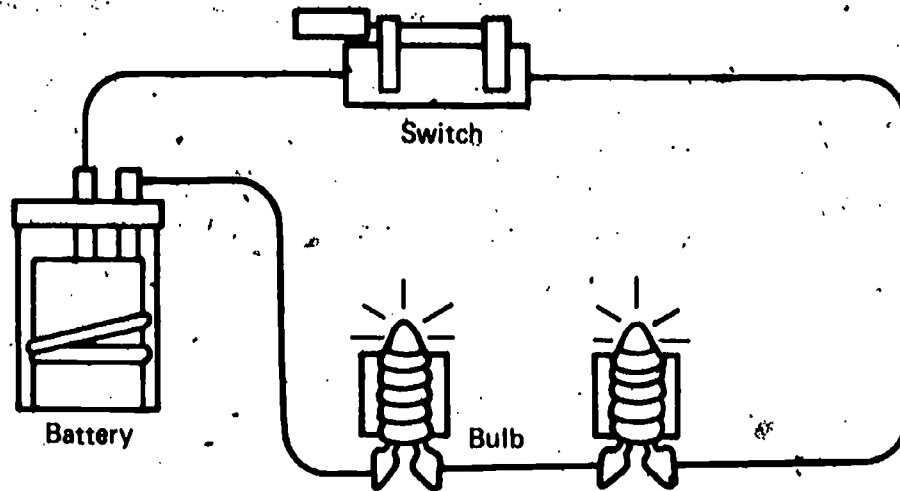

Each diagram below represents either a series or a parallel circuit. On your paper, beside the number of each diagram, name the type of circuit it shows.

06-Core-15B

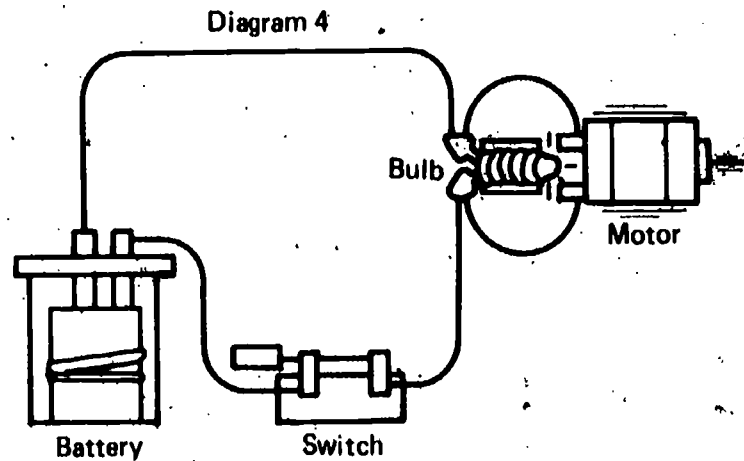
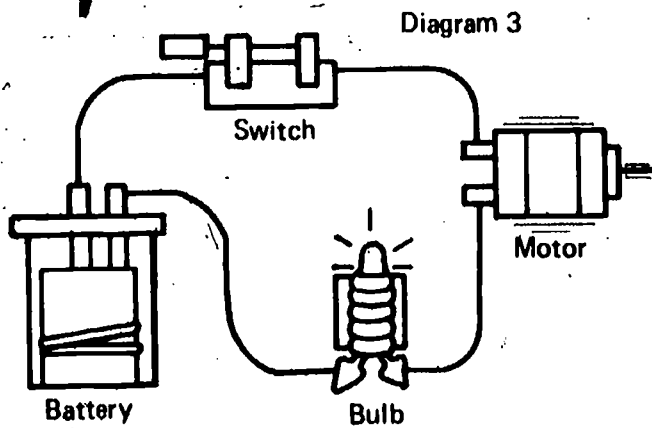
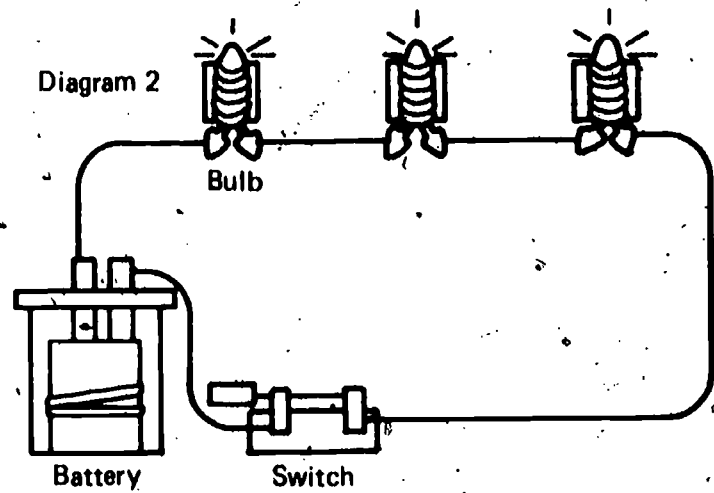
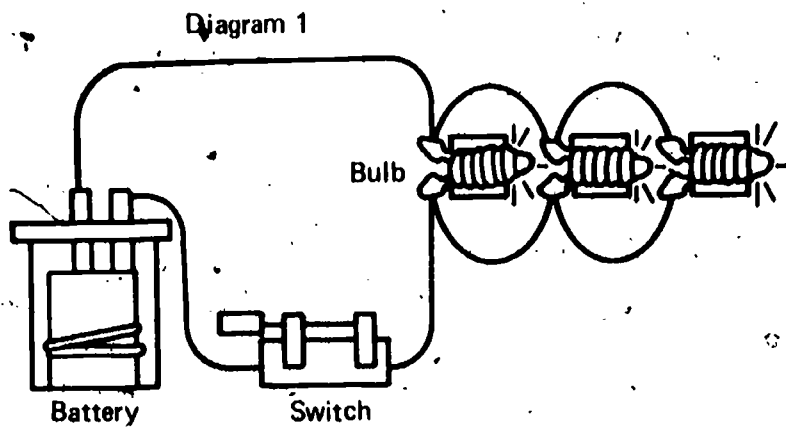

06-Core-16B

Passing electricity through a resistor causes the temperature of the resistor to rise. Why does this happen?

06-Core-17B

Look at the diagram below. A wire coil of about fifty turns of copper wire is hung from a support so that it can move freely. A magnet is brought near the coil without touching it. What will happen when the switch is closed?

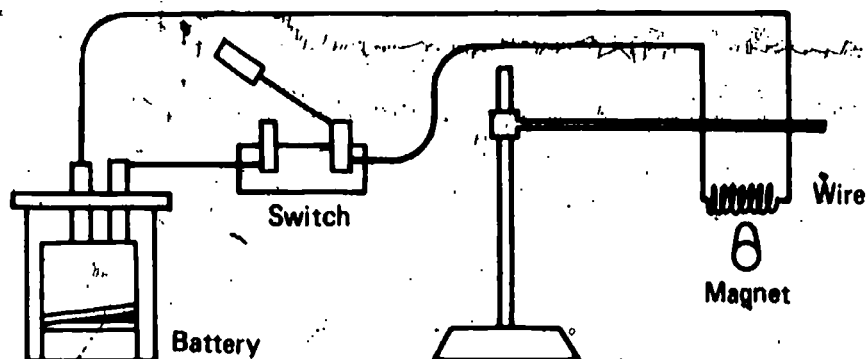

06-Core-18B

In what way is the magnetic strength of a coil of wire changed by changing the number of loops in the coil?

06-Core-19B

Record the letter of each statement below which identifies a characteristic of energy. Energy can

- be destroyed.
- exist in more than one form.
- be transferred from one system to another.
- be measured by speed multiplied by distance.

06-Exc 23-1B

This battery, as it is pictured, will not produce enough electricity to light a bulb. Write the letter of any change listed below which would let the battery produce more electrical energy.

- Using strips made of different metals
- Using a cardboard divider
- Using a test tube rather than a battery jar
- Using a different solution, such as copper sulfate

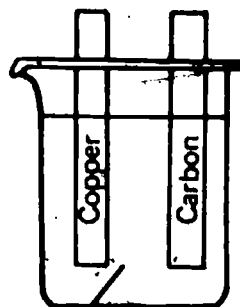

Ammonium chloride solution

Chemical energy can be stored and then changed to other forms. Write the letter of any sentences below in which it is possible to say that the stored chemical energy is changing to other forms.

06-Exc 24-1B

- The brown coating on the lead strip in your ISCS battery disappeared when electricity was produced.
- A black substance appeared when zinc metal was placed in copper sulfate solution and the solution got hot.
- Bubbles appeared around the zinc metal strip when it was placed in copper sulfate solution.
- None of those are correct.

Sonia measures the length of a copper electrode using a wooden meterstick. She gets a length of 18.2 cm. Next she measures the electrode, using a plastic ruler, which is more precise. She gets a length of 18.28 cm. Finally, she uses an engineer's metal ruler, which gives her a length of 18.275 cm. Sonia says now she knows that the 18.2 cm length she recorded earlier is in error and that the length of the electrode is exactly 18.275 cm.

06-Exc 25-1B

- Do you agree or disagree with Sonia?
- Why?

Chris plotted points for data he collected using a spinigig. The points were located as shown on the grid below. Get grid paper from your teacher. Label the axis, and plot the points as shown below. Then draw the best-fit line for the points.

06-Exc 25-2B

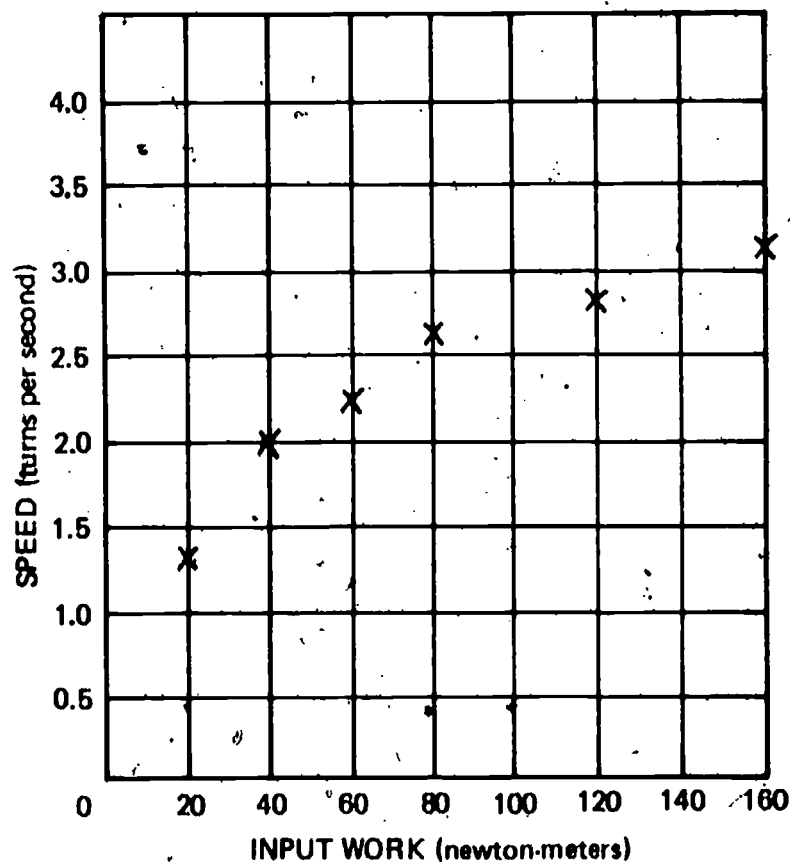

**06-Exc 26-1B**

The electrical outlets in Iggy's house are wired in parallel. Write the letter of the sentence below that explains what that means.

- a. The circuit contains more light bulbs than if it had been wired in series.
- b. The electricity can flow through the circuits in any one of several paths.
- c. If the TV is switched off, the popcorn popper will stop popping.
- d. The TV, stove, and stereo will work whether or not they are switched on.
- e. All of the above are correct.

**06-Exc 27-1B**

The following diagram shows a copper wire passing through a piece of wood on which several compasses have been placed. On your answer sheet, trace the wood and compasses. Then, use arrows to show the direction the compass needles will point when the switch is closed and electricity is passing through the wire.

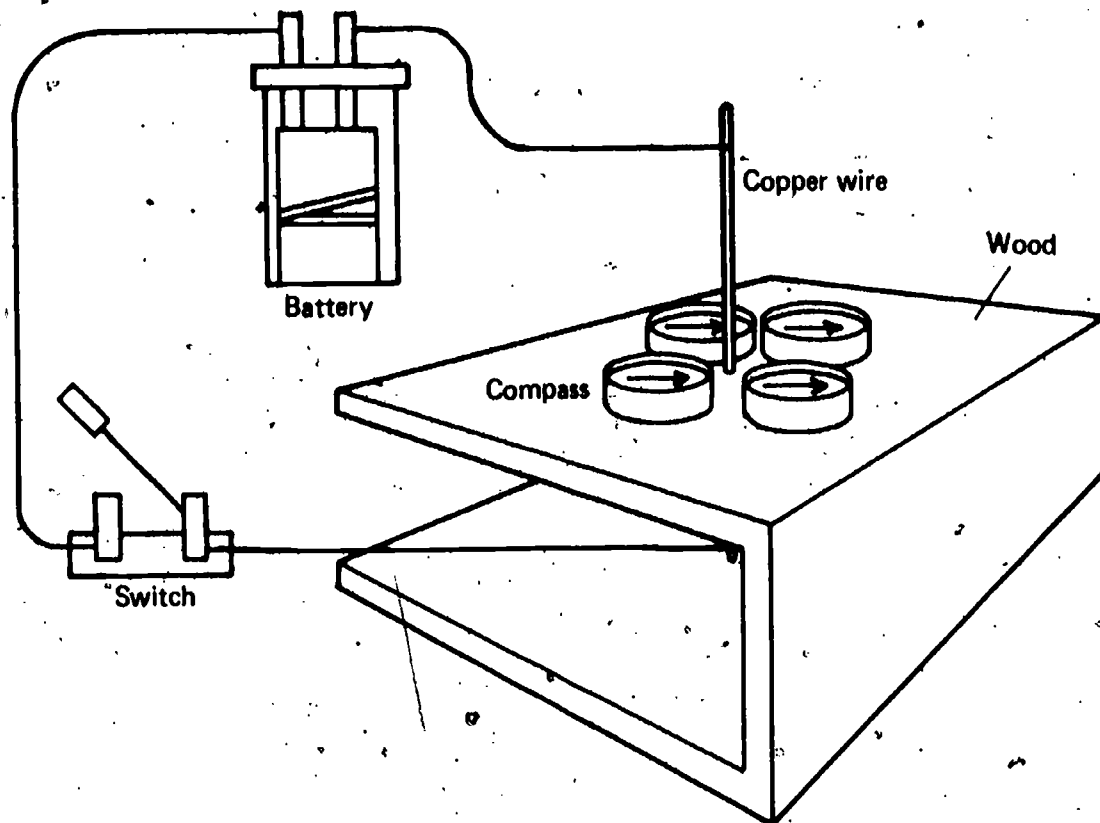

Select the answer which is not true of a scientific model.

07-Core-1B

- a. It is useful.
- b. It explains observations.
- c. It may in some cases be represented by a physical object or a sketch.
- d. It is an experimental observation.

Select the best answer. Scientific models come into existence by being

07-Core-2B

- a. extracted from nature, using microscopes.
- b. discovered in nature, using telescopes.
- c. thought up by men, using their observations.
- d. found among data and pieced together.

What are two things a good scientific model does?

07-Core-3B

Select the statement below which best fits your understanding of the models that scientists use. A scientific model

07-Core-4B

- a. cannot be shown to be incorrect.
- b. provides correct answers to all scientific questions.
- c. describes what actually happens in nature and therefore is correct.
- d. is not used because it is correct, but because it is useful in explaining observations and predicting other observations.

The ISCS model for electricity explains electricity by using the idea of an electroparticle. Name three things about the electroparticle that are assumed to be true.

07-Core-5B

Assume that the electroparticle model explains electricity. On your answer sheet, describe the path through the battery-battery charger circuit that we assume electroparticles follow. Tell what happens to the electroparticles at each step as a battery becomes charged.

07-Core-6B

High energy terminal

Low energy terminal

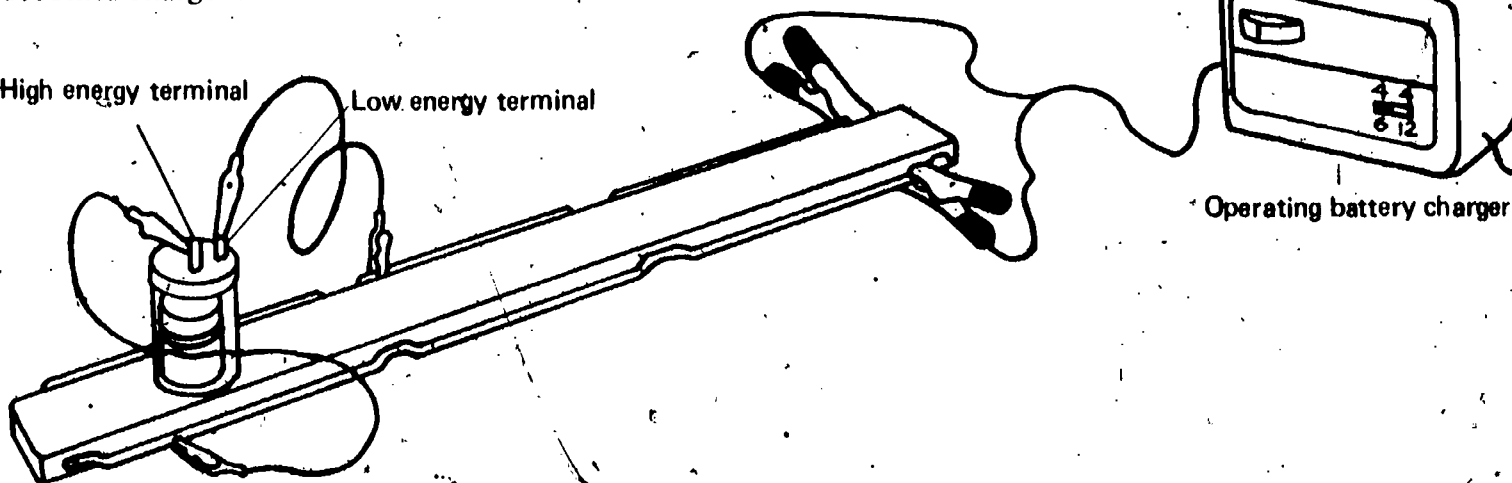

Dr. Alice Pierce wants to explain gravity in terms of a new model. Can more than one model be developed which can be used to explain gravity? If not, why not? If so, how would a scientist decide which model to use?

07-Core-7B

**07-Core-8B** Describe the process of charging a battery, using the electroparticle model to tell what happens.

**07-Core-9B** When a charged battery is connected to an electric bell and the circuit is complete, the bell rings. Using the ISCS electroparticle model, explain how the energy travels through the circuit and how it makes the bell ring.

**07-Core-10B** Think of the ISCS electroparticle model for electricity, and tell what happens at the poles (terminals) of a battery. The battery is part of a complete circuit to a bell.

**07-Core-11B** What is the effect of adding a resistor to a circuit through which current is flowing? Use the electroparticle model to explain what happens.

**07-Core-12B** A circuit contains a charged battery, a light bulb, and a resistor. Select the factor below which determines how many electroparticles will pass through the resistor in two minutes if the battery has a good charge.

- The size of the electroparticles
- The size of the light bulb
- The energy of each electroparticle
- The charge of the battery

**07-Core-13B** The ISCS electroparticle model does not answer several questions about electricity flow. List three of them.

**07-Core-14B** An ammeter must be connected in series with a circuit to measure the current the circuit receives. Why?

**07-Core-15B** Study the diagram below to determine how the electricity measurer is connected in the circuit. When it is connected in this manner, what does it measure?

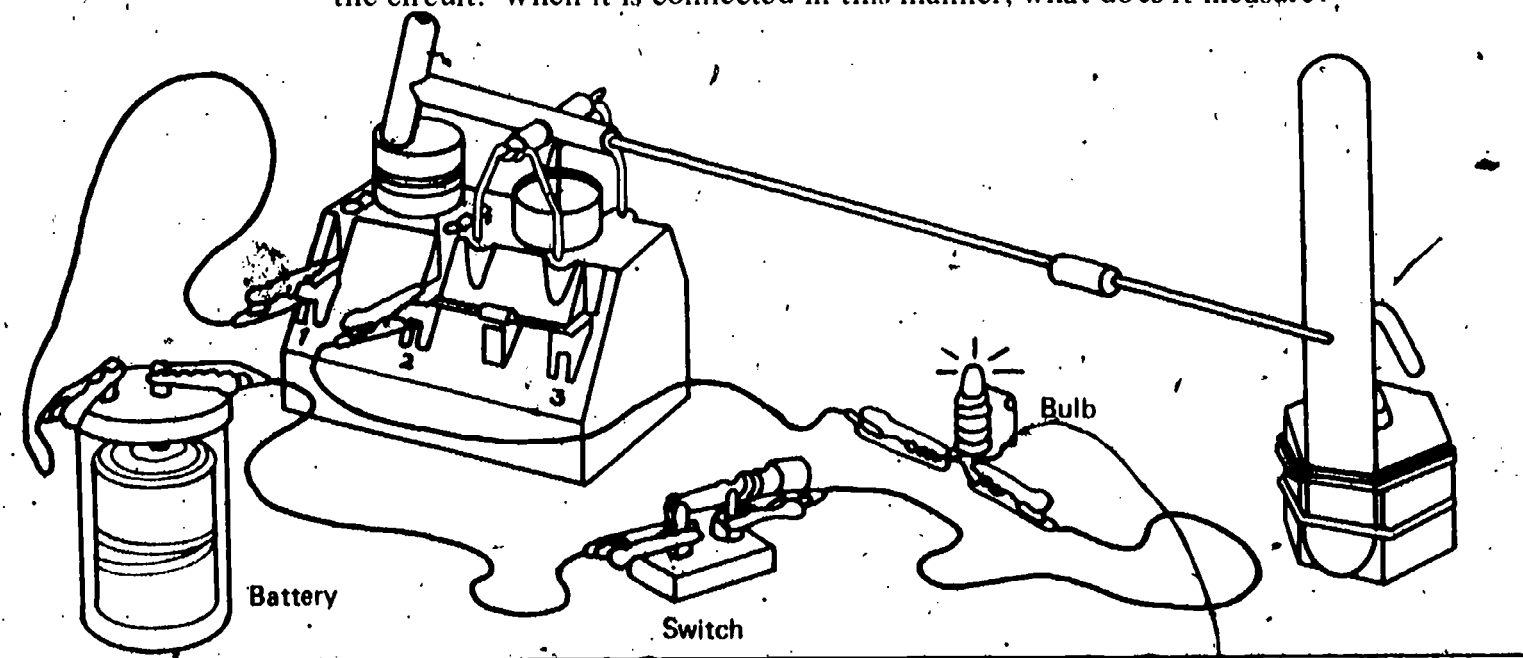



Select the best answer below. Accepted units of measurement come into existence when they are

07-Core-16B

- a. set by nature.
- b. experimentally discovered by scientists.
- c. defined by people.
- d. found by experience.

One way to describe electricity is to use the electroparticle model. Describe the process of charging a battery, using this model.

07-Core-17B

What is the standard unit for measuring electrical current?

07-Core-18B

Name the unit of measurement used as a standard for measuring electrical energy carried by an electroparticle.

07-Core-19B

Carefully study the setup your teacher has assembled in box 07-Core-20. As it is set up, it is an ammeter. Change it to a voltmeter. Show your setup to your teacher.

07-Core-20B

Get an ISCS electricity measurer kit, four D batteries in holders, five test leads, and a blank tongue depressor mounted on a  $\frac{1}{2}$  kg mass with rubber bands. Using these materials, make a voltmeter scale for the electricity measurer.

07-Core-21B

1. Construct circuit A. Close the switch and measure the current flow, and report your measurements. Show your ammeter hookup to your teacher.
2. Now hook up circuit B. Close the switch and measure and record the total current flowing in the circuit. Show your hookup to your teacher.

07-Core-22B

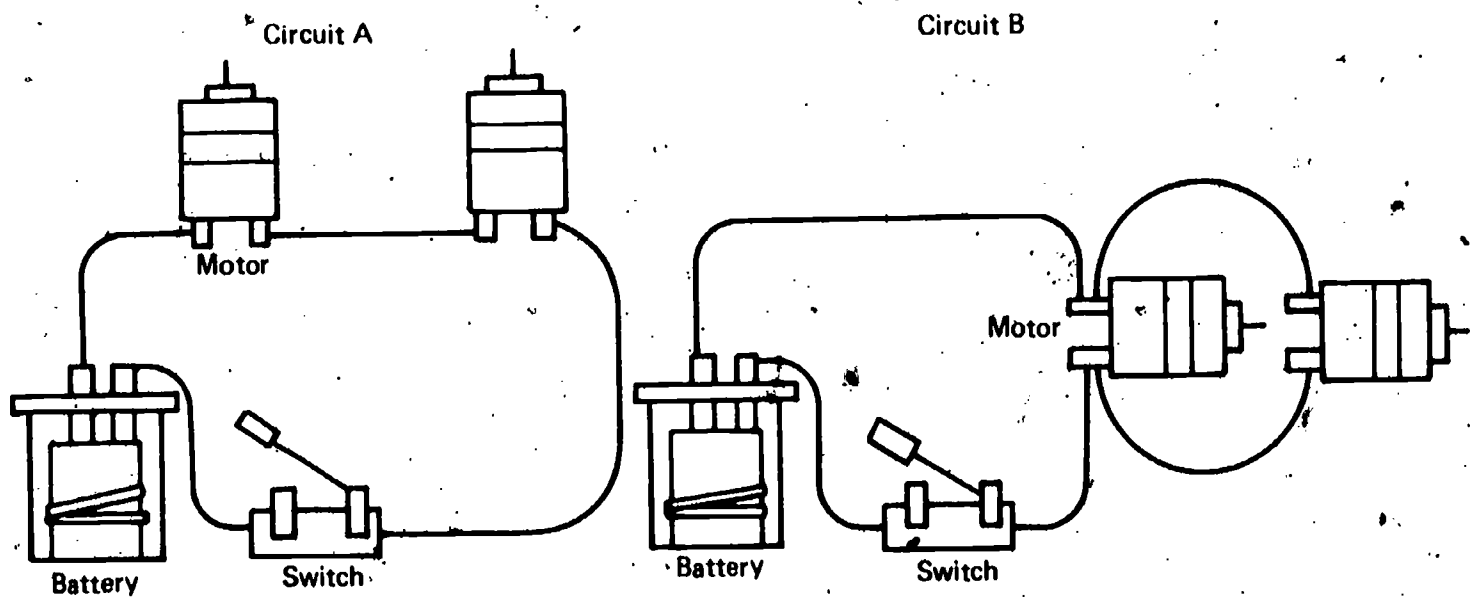

07-Core-23B

Suppose you connected an electricity measurer to a circuit, closed the switch, and the pointer moved in the wrong direction, as shown in the diagram. What should you do to cause the meter pointer to move in the other direction?

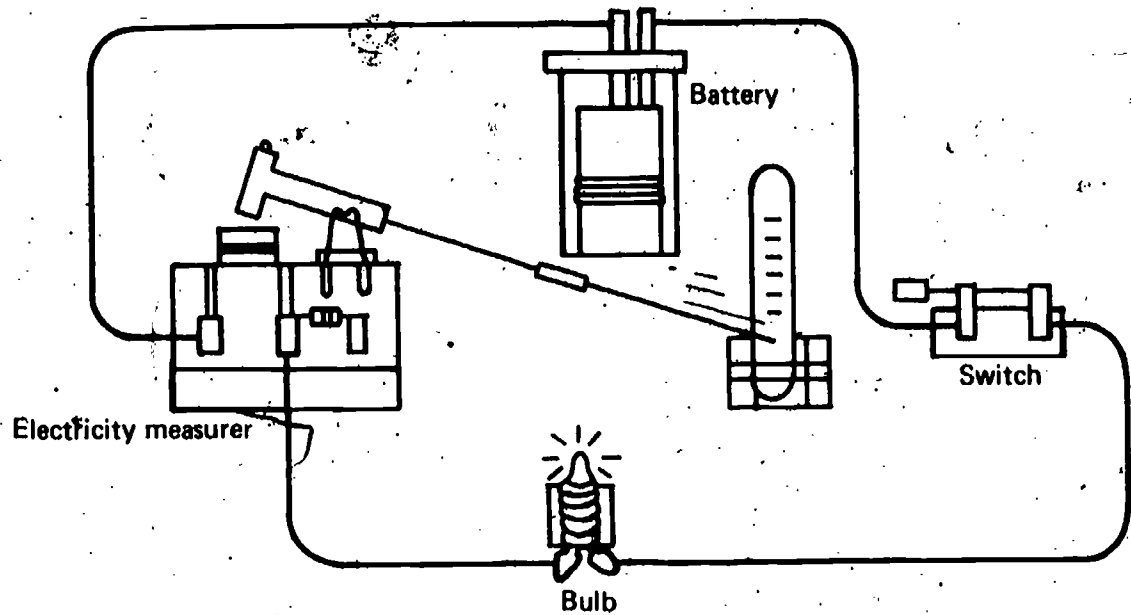

07-Core-24B

How will adding an additional motor in series in this circuit affect the amount of electrical energy each of the bulbs receives?

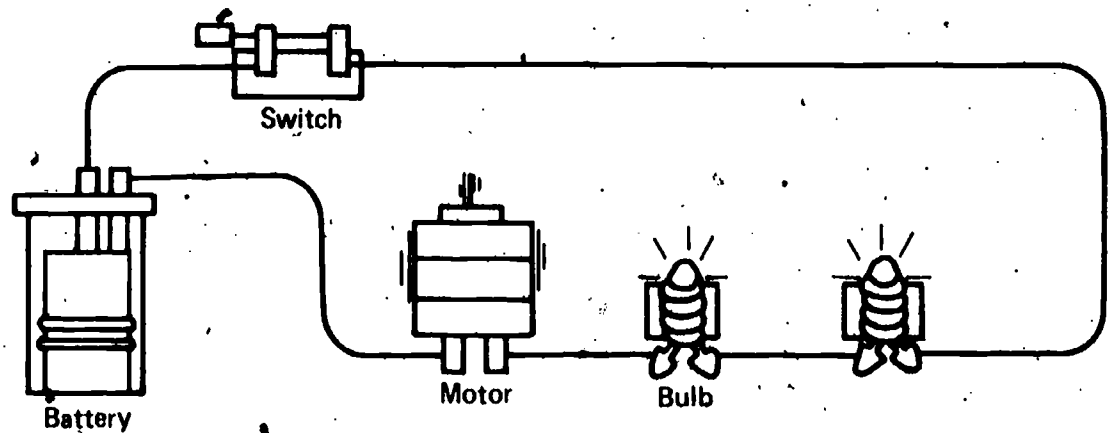

---

A returned Apollo space capsule is in the Pacific waiting to be picked up. As a helicopter hovers overhead, it drops Navy frogmen into the water. Their drop produces waves that pass under the floating capsule. Which of the following statements best describes the motion of the space capsule on the water?

07-Exc 28-1B

- a. Up and down in nearly the same spot
- b. Away from the helicopter
- c. Towards the helicopter
- d. Impossible to answer unless you know if the waves are moving away from or towards the helicopter

---

Get a water trough, and fill it with 2 inches of water. Put a cork in the middle, and cause waves by slowly tapping the water surface with a pencil at one end of the pan. Does the cork-water system move horizontally across the tank away from or toward the wave source, or doesn't the system move horizontally at all? What, if anything, does travel across the surface of the water?

07-Exc 28-2B

---

Read the following story. Assume that both persons are stating correct facts. Vic Volt builds stereo systems. He uses the electroparticle model of electricity, which explains all his observations. Because of the model, Vic is very successful in selling his sets. One evening, a friend tells him that he has heard about the new vita electricity model which is more complete, but very complicated. Would the friend be right to say that because the electroparticle model is less complete, it is wrong and should never be used? Explain your answer.

07-Exc 28-3B

---

Select the best answer below. The photon, one of the smallest units of matter possible, is a model proposed to explain some of the behavior of light. Most scientists will accept the photon model

07-Exc 29-1B

- a. if a photon of light is the only way to explain light.
- b. if law decrees that the photon is the smallest particle of matter and will explain light.
- c. if thinking about light as made up of photons is useful.
- d. only if the photon is observed in experiments.

---

Pretend that in 1970 a science text stated that the wave model for gravity was accepted by most scientists. This would mean that

07-Exc 29-2B

- a. they had direct proof that gravity traveled in waves.
  - b. thinking about gravity as though it traveled in waves explained the observations made to that date.
  - c. at least a few scientists had observed gravity traveling as waves.
  - d. gravity had the exact properties of a water wave.
  - e. no other model could fit the observations made to date.
-

07-Exc 29-3B

Pretend that nearly all scientists accept the electroparticle model of electricity described in Excursion 29. Choose the sentence below which best describes one of the things that acceptance implies.

- a. No other model could fit the observations made to date.
- b. It answers all their questions about electricity.
- c. The model must be revised to incorporate any new observations that don't agree with it.
- d. At least a few scientists have seen electricity traveling as electroparticles.
- e. None of the above are correct.

07-Exc 30-1B

Two wires, A and B, are positioned as in Diagram 1 when the switches are open. Diagram 2 shows that when the switches are closed, wires A and B will repel each other. Suppose that in Diagram 2 in the circuit containing wire A the electroparticles come out of the battery through terminal 1 and reenter the battery through terminal 2.

- 1. Through which terminal in the circuit containing wire B do the electroparticles come out of the battery?
- 2. Through which terminal in the circuit containing wire B do the electroparticles go back into the battery?

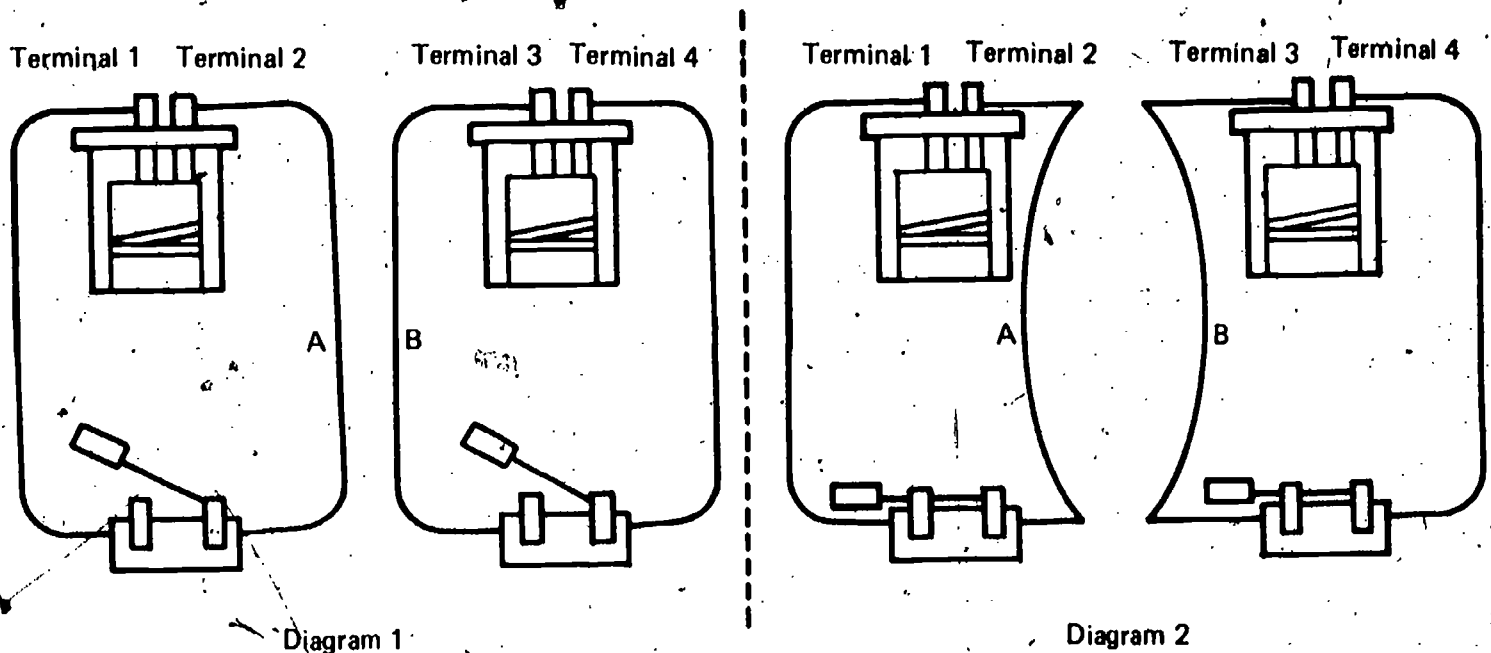

07-Exc 31-1B

Which of the following statements is the best description of scientists?

- a. Scientists are the only group of people that forget easily.
- b. Scientists are so involved in their work that they do not have time to be polite.
- c. Scientists are completely different from other people.
- d. Scientists' personalities vary like the personalities of any group of people.
- e. Scientists all exhibit behavior patterns like Ampere's.

---

A battery-operated model racing boat is manufactured by the same toy company that manufactures a battery-operated model pleasure boat. Each model boat runs on two batteries. The racing model runs much faster, but not nearly as long, as the model pleasure boat.

**07-Exc 32-1B**

For each boat, state whether the batteries are connected in series or in parallel. Explain your choices, using the electroparticle model.

---

A toy manufacturer decides to improve his model train which operates on two batteries connected in parallel. The motor that turns the wheels and the motor that operates the flagman can be thought of as two resistors. The new improved model train is to have a freight loading device. This extra movement will require a third motor (resistor), and a third battery wired in parallel. Will a voltmeter reading taken on the new improved model train be more than, equal to, or less than a voltmeter reading taken on the older version of the model train? Explain your answer, using the electroparticle model.

---

**07-Exc 33-1B**

A toy manufacturer decides to improve his model speedboat which operates on two batteries and motors connected in series. The motor that operates the propeller and the motor that operates the boat's lights can be thought of as two resistors. The new, improved model speedboat is to have a man turning the wheel. This movement will be caused by another motor – a third resistor, the same size as the other two. In addition the manufacturer plans to add a third battery in series. Will an ammeter reading taken in the new, improved model speedboat be more than, equal to, or less than an ammeter reading taken in the older model? Explain your answer, using the electroparticle model.

---

**07-Exc 33-2B**

An ammeter must be connected in series with a circuit to measure the current flow through the circuit. Use the electroparticle model to explain why it must be connected in series rather than in parallel with the circuit.

08-Core-1B

If you need to know the voltage available to a bulb in a circuit, how should a voltmeter be connected into the circuit? If you wish, you may use a diagram as part of your answer.

08-Core-2B

Study the circuit below. Describe how you could detect and measure voltage at the bell when the switch is closed. Name any other piece of equipment you may need. Tell which letters on the diagram show the places where the equipment should be connected.

08-Core-3B

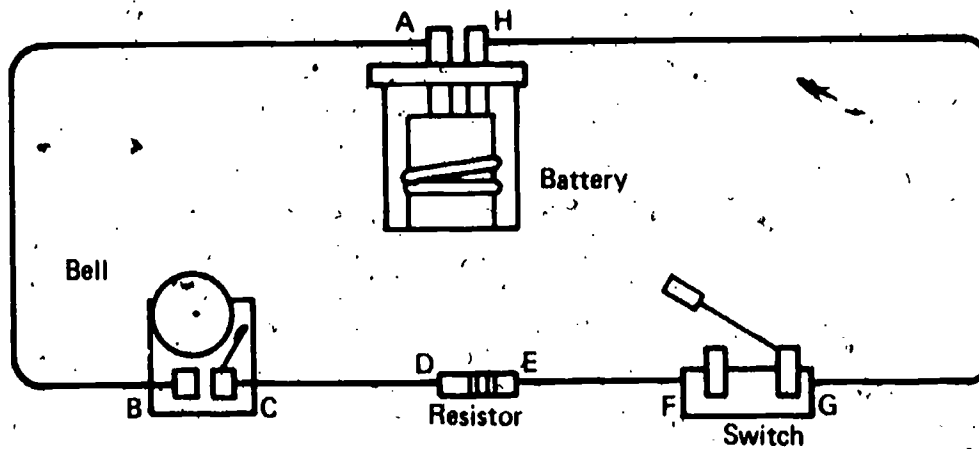

In the diagram below, the meters are correctly connected to measure current and voltage. Decide for yourself how each meter is connected and whether it is an ammeter or a voltmeter. Then, record on your answer sheet the words in parentheses that best complete the statements below.

08-Core-4B

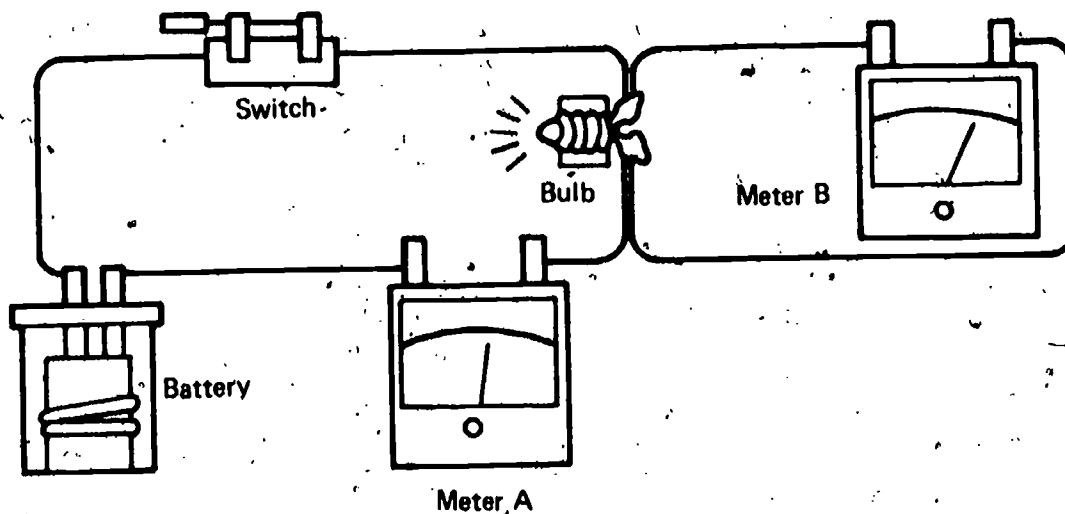

1. Meter A is connected in (series, parallel) with the light bulb. Therefore, Meter A is (an ammeter, a voltmeter).
2. Since Meter B is connected in (series, parallel) with the light bulb, it is (an ammeter, a voltmeter).

08-Core-5B

A light bulb receives 0.5 amperes and 5 volts for 20 seconds. Find the total electrical energy received by the bulb. Show your work, and use the correct units.

08-Core-6B

Choose the correct answer below. What is the formula for calculating the total electrical energy supplied in a given circuit?

- Volts times amperes times time
- Volts divided by amperes divided by time
- Volts times amperes divided by time
- Volts plus amperes plus time

08-Core-7B

Below is a diagram of a complete circuit in which a motor is running. List the three variables that you must measure to determine the total amount of electrical energy the motor receives.

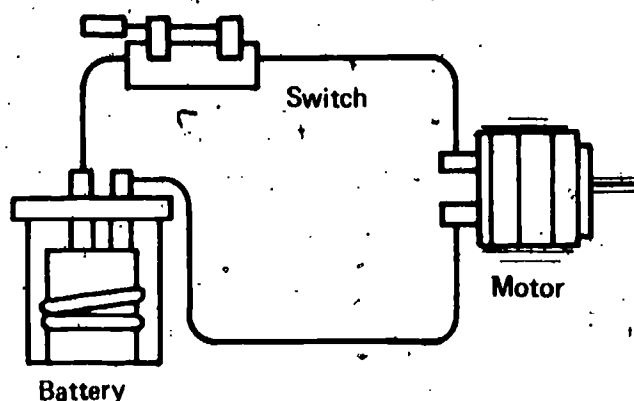

08-Core-8B

Get the assembled circuit in box 08-Core-8B, an electricity measurer, a timer, voltmeter and ammeter scales, and two test leads. Disconnect the battery, charge it, and replace it in the circuit. Measure how much electrical energy is supplied to the motor in the bulb-motor arrangement in a fifteen-second period. Report your measurements and calculations.

08-Core-9B

Dr. Crawler had two students do a project on spiders. Their observations are shown in the chart below.

Student	No. of Species	No. of Species Seen on Dirt	No. of Species Seen on Leaves	No. of Species Seen on Grass	No. of Species Seen Dead
Tanya	lots	few	most	some	very few
Rene	27	4	15	6	2

Give two reasons why scientists prefer the kinds of observations Rene made.

Select the examples below in which electricity does observable work. Electrical energy

08-Core-10B

- a. lights a bulb.
- b. operates an electric lawn mower.
- c. operates a fan.
- d. heats a burner on an electric stove.
- e. operates a record player.

The diagrams below are of two electrical circuits labeled Circuits A and B. Get a voltmeter and the materials to construct the circuits. After constructing the circuits as shown, measure the voltage across each entire circuit. Record the voltages, and show your setup to your teacher. Be sure your battery is charged before you make your measurements.

08-Core-11B

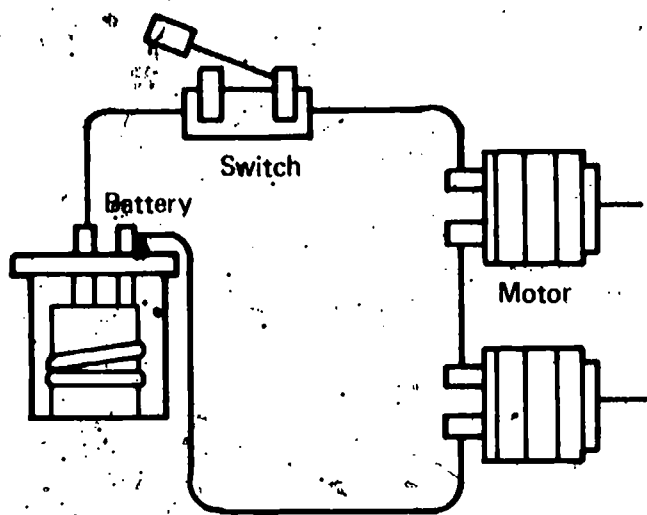

Circuit A

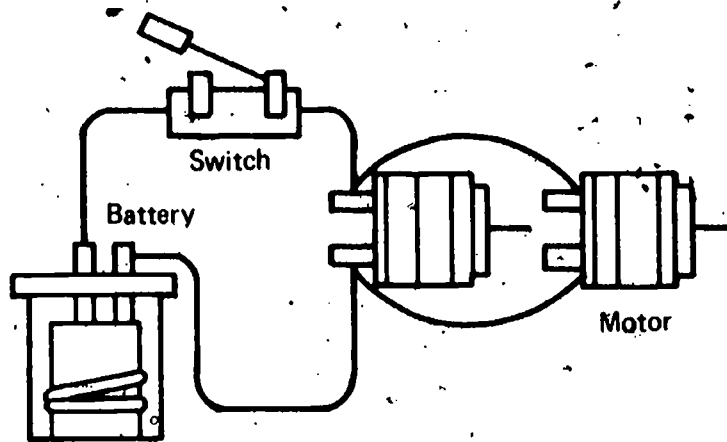

Circuit B

Circuits A and B are shown below. Each contains one ISCS battery and four resistors connected by test leads. However, Circuit A has more resistance to current flow than Circuit B. All resistors in Circuits A and B are the same. Why does Circuit A have more total resistance than Circuit B?

08-Core-12B

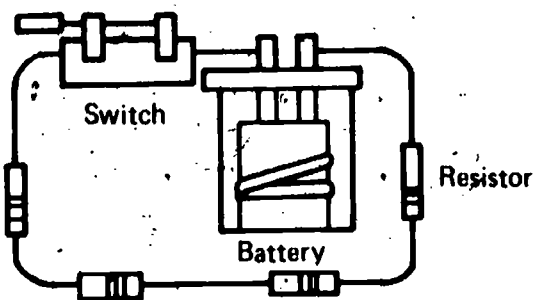

Circuit A

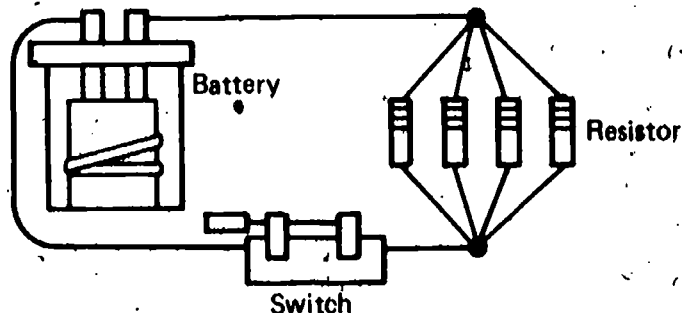

Circuit B



08-Core-13B

Both Circuit A and Circuit B below have identical components, but they are connected differently. Select the phrases in parentheses which best complete the sentences.

1. In Circuit A, the current flows through (each resistor by a separate path, all resistors one after another).
2. In Circuit A, the total resistance to current flow is (less than, greater, than) the current flow in Circuit B.

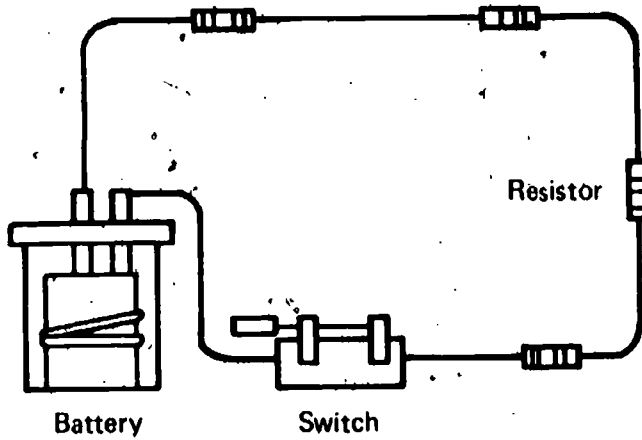

Circuit A

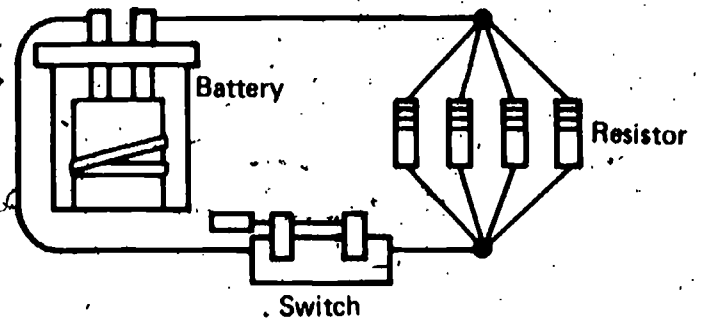

Circuit B

08-Core-14B

Operationally define *battery energy*, using the equipment shown below. (Hint: Remember that an operational definition answers two questions.)

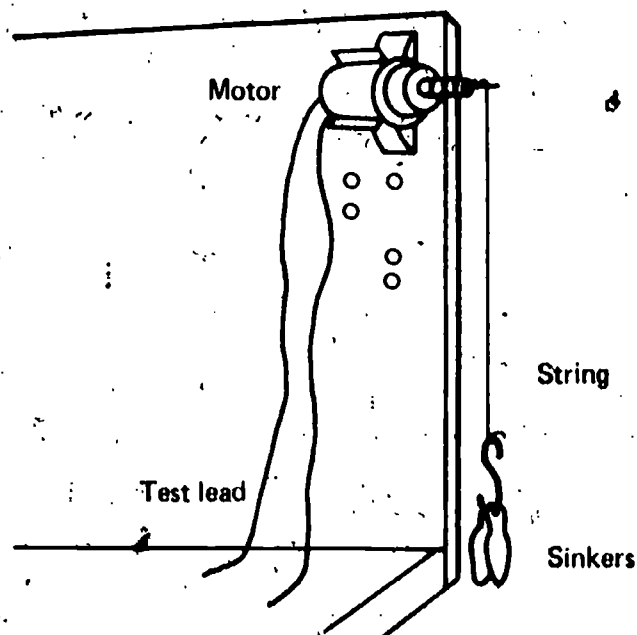

In the following problem, let the cans of beans stand for energy being supplied from one location to another. After the number of each question write the letter of the statement below which answers it best.

08-Exc 34-1B

A large number of No. 2 cans of beans are to be removed from a box on one side of a store and stacked on a shelf on the other side of the store.

1. Which part of the operation is most like a volt?
  2. Which part of the operation is most like an ampere?
  3. Which part of the operation is most like an electroparticle?
- a. The number of persons available to move the cans
  - b. The number of cans a person can carry at one time
  - c. The length of time a person works
  - d. The number of cans put on the shelf per hour
  - e. The quality of the beans

There is a floor lamp next to Iggy's favorite reading chair. Record the letters of all the variables in the list below which affect the power received by the bulb when it is turned on.

08-Exc 35-1B

- a. There is a known number of newton-meters of energy in an electroparticle.
- b. The bulb is a soft-white bulb.
- c. The voltage reading at the lamp is 120 volts.
- d. The central air conditioning unit is out of order, and therefore is not using power.
- e. The current flowing through the lamp is one ampere.
- f. The bulb releases 25 calories of heat per minute.

Set up the circuit as shown in the diagram. Be sure you use a freshly charged battery. Then connect one electricity measurer as an ammeter and the other as a voltmeter to measure the current flow and voltage of this circuit. Calculate the power of the circuit. Record your answer, and show it to your teacher before you dismantle your setup.

08-Exc 35-2B

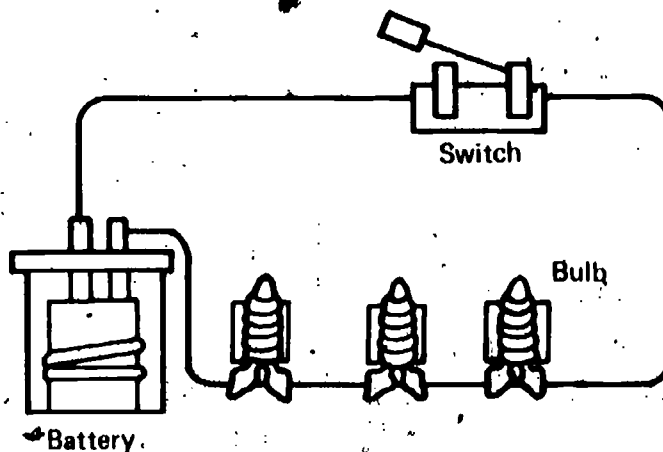

---

**08-Exc 36-1B**

The wires in Bernice, a toy bunny, are all made of the same thickness of copper. The resistance of the wire is 4 ohms when the voltage is 12 volts and the current is 3 amps. A different model of Bernice is identical except that more batteries are required, thus producing more voltage and current. What would you expect the resistance of the wire to be in this version of Bernice – more than, equal to, or less than 4 ohms? Explain your answer, using the electroparticle model.

---

**08-Exc 37-1B**

Get the box labeled 08-Exc 37-1. What will happen if the untaped magnet is turned so that its untaped end is away from the coil? Explain your answer.

---

**08-Exc 38-1B**

The motor of a model helicopter causes the helicopter to rise straight up. What would you need to know to determine how much work the toy's motor can do in one minute?

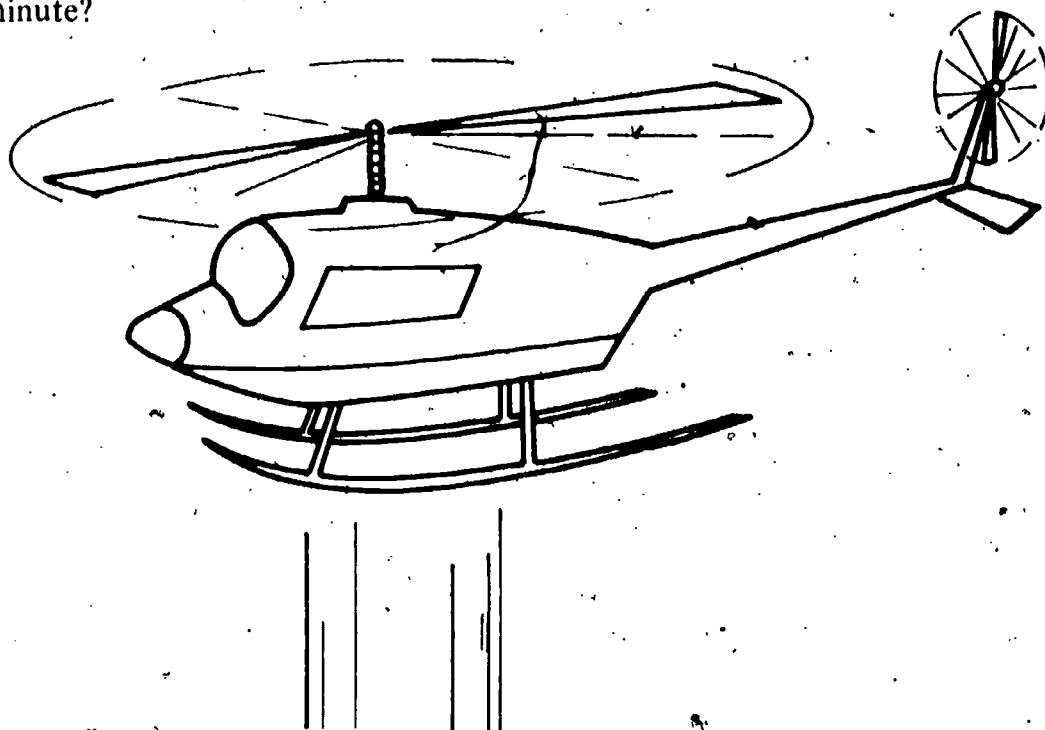

---

**08-Exc 39-1B**

You may refer to Excursion 39 to answer this question. In it, you were told: "You have learned about electricity from activities like the ones in the textbook without too much trouble. It was the explorers who had a hard time." What helps have you had in learning about electricity that the explorers didn't have that makes your learning about it easier?

---

Fill the air piston with water to the 4.0 cc mark. Then show the air piston to your teacher.

09-Core-1B

Box 09-Core-2 contains an air piston partly filled with a liquid. Look at the air piston, and record the volume of liquid in it.

09-Core-2B

Which of the choices below will result when you increase the temperature of water?

09-Core-3B

- The water will increase in mass.
- The water will increase in volume.
- The water will change color.
- The water will glow.

A company needs to design a device which will show very tiny changes in temperature and which will have the temperature marks on the scale be rather widely spaced. Which of the following would make the best expanding substances for such a device?

09-Core-4B

- Glass
- Oil
- Oxygen
- Alcohol

Explain why the freezing point of water can be both  $32^{\circ}$  and  $0^{\circ}$ , as shown on the Fahrenheit and Celsius thermometer scales below.

09-Core-5B

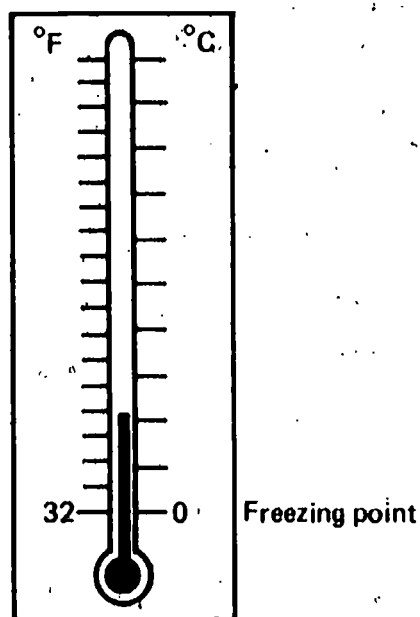

Mrs. Jefferson went to the store to buy a piece of ribbon. She wanted 50 thumbs of the ribbon. The clerk measured the ribbon with her thumb. When Mrs. Jefferson measured the ribbon, using her own thumb, it measured only 48 thumbs. Feeling that she had been cheated by the clerk who measured the ribbon, she went to the manager of the store and complained. What is necessary to avoid such confusion in the future?

09-Core-6B

**09-Core-7B**

Name the standard unit used by scientists and in ISCS for measuring temperature.

**09-Core-8B**

Look at the drawing below. What happens to water when its temperature registers  $0^{\circ}\text{C}$ ? What happens to water when its temperature registers  $100^{\circ}\text{C}$ ?

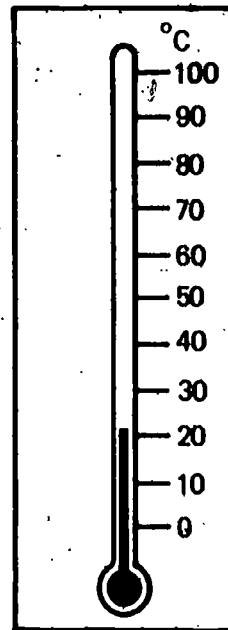

**09-Core-9B**

Get a beaker of copper sulfate solution. Measure its temperature, and report the temperature to your teacher.

**09-Core-10B**

You have used a thermometer that has a liquid in the tube. How does it work?

**09-Core-11B**

When Boyd's mother couldn't get the lid off the olive jar, he told her to put the top of the jar into hot water. After this was done, the lid came off easily. Explain why heating the lid caused it to loosen.

**09-Core-12B**

A sample of liquid water, whose mass was known, was heated for several minutes. Its temperature was taken before and after heating. Write an operational definition for the change of heat content of the sample.

**09-Core-13B**

How many calories are required to raise 35 grams of water from  $30^{\circ}\text{C}$  to  $40^{\circ}\text{C}$  in three minutes?

**09-Core-14B**

A 200 g sample of water was heated for ten minutes, and the temperature was  $25^{\circ}\text{C}$  higher after heating than before. What would the temperature change be if a 100 g sample of water were heated under the same conditions for ten minutes?

- $50^{\circ}\text{C}$
- $12.5^{\circ}\text{C}$
- $25^{\circ}\text{C}$
- $75^{\circ}\text{C}$

---

What is measured with a thermometer?

09-Core-15B

---

Which of the following is a standard unit for measuring heat?

09-Core-16B

- a. calories
- b. temperature
- c. Fahrenheit
- d. Celsius

---

What are two properties of heat that you have observed which support the heat-substance model? The heat-substance model assumes that heat is a substance which can flow between objects and whose quantity determines the temperature of objects.

09-Core-17B

---

The diagram shows that the level of water in the test tube was B before the test tube was heated in the beaker of water. After heating, the water in the test tube rose to level A. The heat-substance model can explain this. From the following list, select the letters of the four statements which support the heat-substance explanation of how heat gets from the burner flame into the water in the test tube. The heat substance must

09-Core-18B

- a. be made up of tiny particles.
- b. be like rays of light.
- c. take up space.
- d. be able to move.
- e. be like friction.
- f. be a force.
- g. move as fast as light or electricity.
- h. have mass.

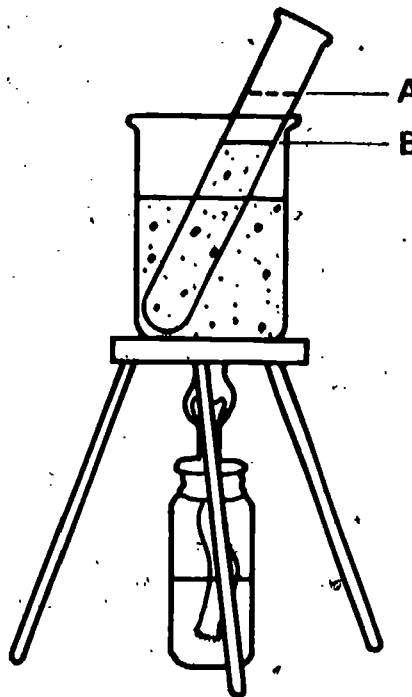

---

Doug proposed the following argument. Cold objects have a cold substance in them. When a cold and a hot object are placed in contact, the cold substance in the cold object flows into the hot object and makes it cooler. An object gets warm, not because a heat substance flows into it, but because the cold substance flows out. Use what you know about heat to show that Doug's argument is false.

09-Core-19B

09-Core-20B

The iron jars labeled A, B, and C are identical. Each has a mass of 40 grams. Assume that A is heated, B is cooled, and C is left at room temperature. Which of the following results would be expected immediately after treatment?

- a. B will weigh more than either A or C.
- b. A will be larger than B or C.
- c. B will weigh less than either A or C.
- d. The size of B will not change.

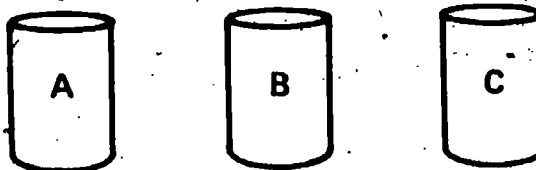

09-Exc 40-1B

Which of the following characteristics make a liquid a bad choice for a thermometer used to measure the temperature of water samples?

- a. A boiling temperature higher than water's
- b. A freezing temperature lower than water's
- c. A boiling temperature lower than water's
- d. Both a and b
- e. A freezing temperature higher than water's

09-Exc 41-1B

If you hear the TV weather girl say that the temperature will drop  $15^\circ$  tonight, does it make any difference whether she means a temperature drop of  $15^\circ$  Celsius or a temperature drop of  $15^\circ$  Fahrenheit? Explain your answer, using information from the diagram below.

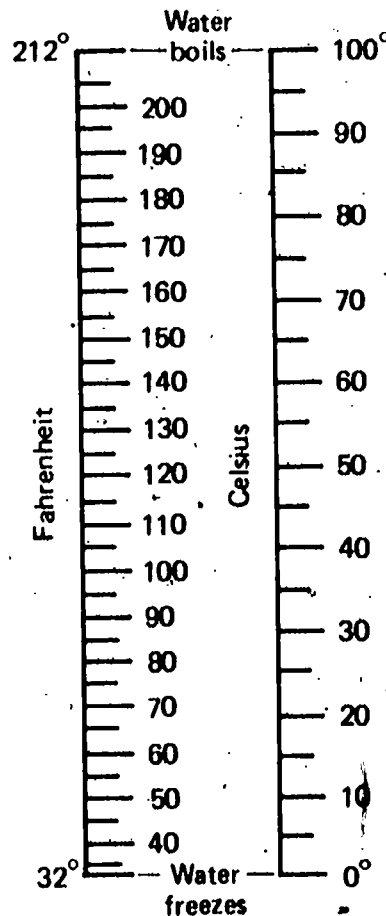

---

Calories are defined using water as a standard. Tell what a calorie is in terms of water.

---

**09-Exc 42-1B**

---

In which climate, arctic or tropical, would your body need to supply more calories? Explain your answer.

---

**09-Exc 43-1B**

---

In each of the following cases, 650 calories were supplied to 800 g of the substance named. Which of these would show the greatest temperature change?

**09-Exc 44-1B**

- a. Hydrogen, whose specific heat is 3.41
  - b. Zinc, whose specific heat is 0.093
  - c. Water, whose specific heat is 1.00
  - d. Nitrogen, whose specific heat is 0.25
-



Assume that four containers of water, A, B, C, and D, are placed in contact with each other as illustrated. Select the response below which indicates the directions of heat flow that occur as the containers touch each other. Ignore the heat lost to the air.

10-Core-1B

- a. A to B, C to B, and C to D
- b. A to B, B to C, and C to D
- c. B to A, B to C, and D to C
- d. B to A, C to B, and C to D

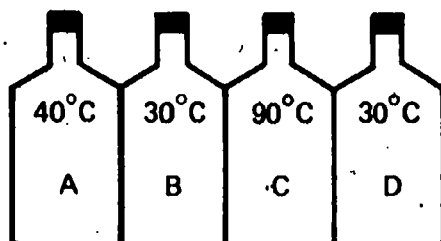

The four containers, A, B, C, and D, each hold the same amount of water. They are placed in contact with each other inside a box which allows no heat to escape. Approximately what will be the temperature of the water in container B after one hour?

10-Core-2B

- a. Between 60°C and 70°C
- b. Between 55°C and 60°C
- c. More than 70°C
- d. Between 45°C and 50°C

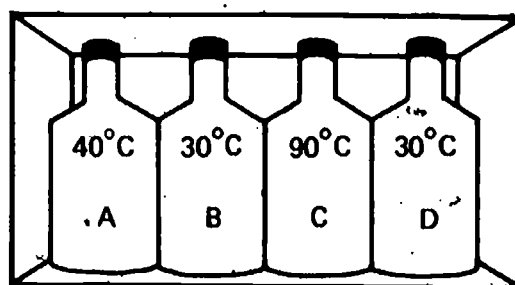

Aluminum can exist as a gas, a liquid, and a solid. In which one of the following states of matter would it be the poorest conductor of heat?

10-Core-3B

- a. Solid
- b. Liquid
- c. Gas
- d. Either a or b
- e. Florida

**10-Core-4B**

Sidney put burners under the three beakers (A, B, and C) at the same time. He also put thermometers into the beakers at equal distances from the heat source as shown.

1. In which of the beakers will the thermometer begin to show changes in temperature first?
2. Why?

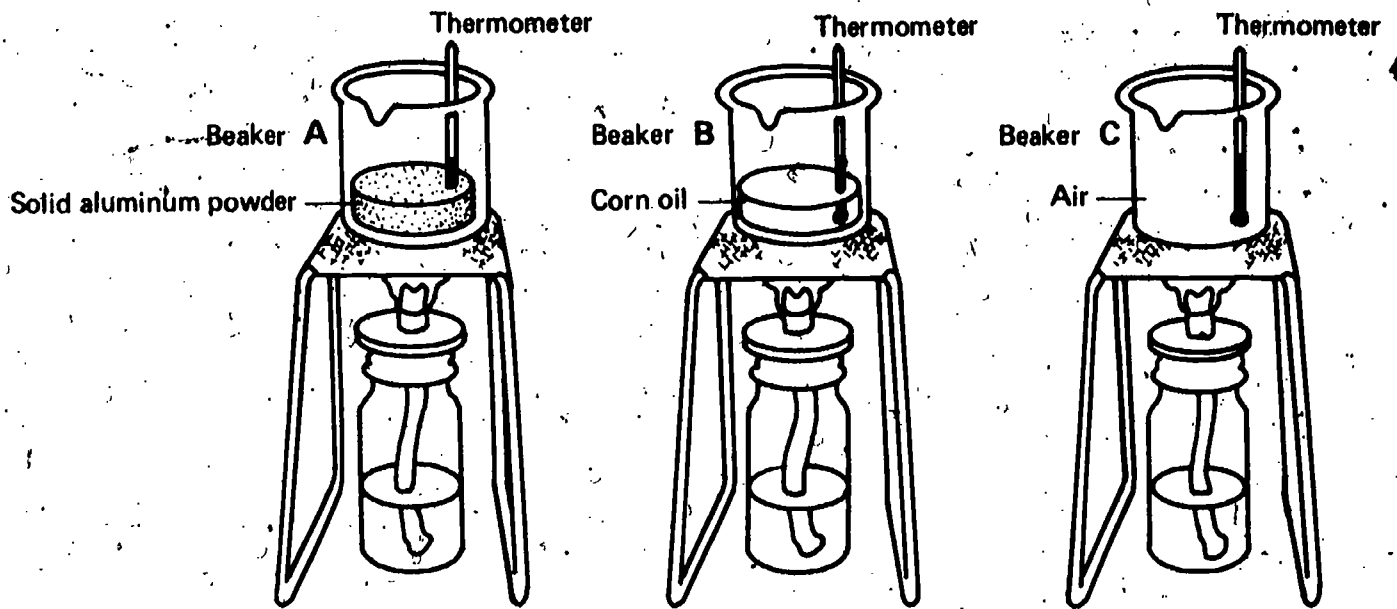

**10-Core-5B**

After completing Activities 20-7 and 20-8, some students felt that it was a weak argument for rejecting the heat-substance model. They said that the balance wasn't very accurate and therefore would not detect any possible small changes in mass. What change would you make in these activities to make it possible to detect small changes in mass?

**10-Core-6B**

Two  $\frac{1}{2}$  kg masses are exactly balanced on the pegboard balance as shown. Suppose the left-hand mass is heated until it gets red hot. The right-hand mass would

- a. move way down.
- b. move down slightly.
- c. not move at all.
- d. move up.

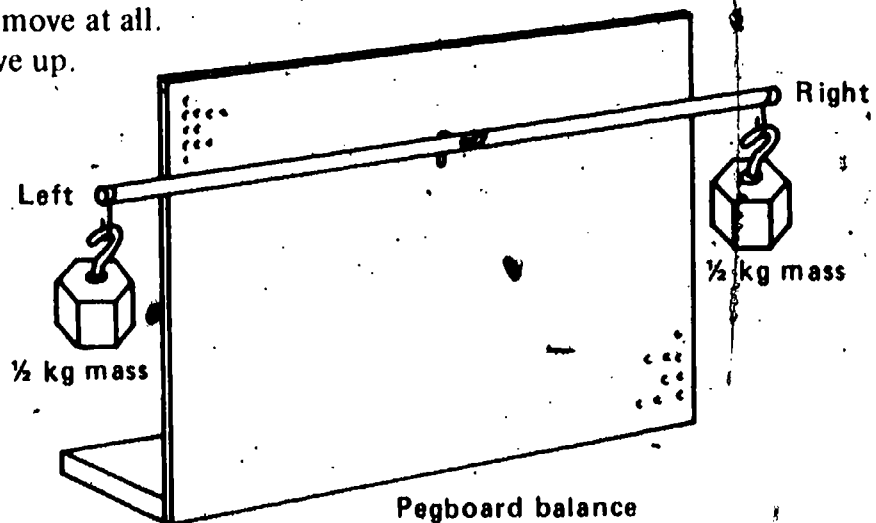

---

In the following story, assume that both doctors' facts are correct. Dr. I.T. Hurtz designs lens systems for microscopes and telescopes. The model he uses assumes that light travels in straight lines except when it goes from one substance to another; then, it bends. Dr. Smith, a physicist, uses a model which says that light is like a wave and does not travel in straight lines.

10-Core-7B

Dr. Smith says to Dr. Hurtz, "Your model and equations aren't used by scientists anymore. The model does not fit all the observations made, and it does not suggest further experiments."

Dr. Hurtz answers, "The model I use explains all the observations included in the optics of lens making. Furthermore, the arithmetic involved is fairly simple and quick. If I used the equations involved in the wave theory, a super nova would come and go before I could complete the proper lens system for a telescope."

1. Should Dr. Hurtz stop using the older model and use the newer, broader model which explains more light phenomena?
2. Explain your answer.

---

Select the best answer. The models of science come about by being

10-Core-8B

- a. discovered under microscopes.
- b. invented in the minds of people.
- c. found in the data of experiments.
- d. observed directly in nature.

---

Select the letter of the phrase below which best completes this sentence. Scientists use the heat-as-energy model because it

10-Core-9B

- a. provides correct answers to all questions about heat.
- b. helps to explain observations and to predict other observations.
- c. is correct because it comes from nature, and nature is always right.
- d. can predict new experiments even though it cannot explain observations made with the heat-substance model.

---

Scientists use the heat-as-energy model to explain heat. They use it because

10-Core-10B

- a. they have direct proof that heat is energy.
- b. thinking about heat as though it is energy explains most of the observations made to date.
- c. at least a few scientists have seen heat as energy with their own eyes.
- d. no other model could fit the observations made to date.
- e. heat has the exact properties of a wave.

**10-Core-11B**

Heat-as-energy and heat-substance are two models used to explain heat. Study the chart below, and then answer the two following questions.

SITUATION	CAN BE EXPLAINED BY	
	Heat-as-Energy	Heat-Substance
Rubber doesn't gain weight when heated.	X	
Carbon dioxide expands when heated.	X	X
Spaghetti tastes better when hot than when cold.		
Cement expands when heated.	X	X

1. Based on the information in the chart, which is the better model?
2. Explain your answer.

**10-Core-12B**

Patriciá measured a liquid, as pictured in Diagram A below. She heated the liquid and then immediately remeasured its volume. The volume of the liquid after heating is shown in Diagram B. Using the heat-substance model, explain the results.

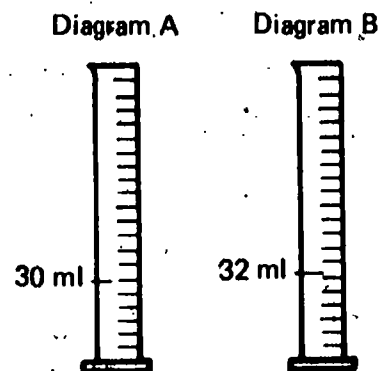
**10-Core-13B**

Phyllis measured a liquid as pictured in Diagram A shown below. She heated the liquid, and then remeasured its volume. The results are shown in Diagram B. Using the heat-as-energy model, explain the results.

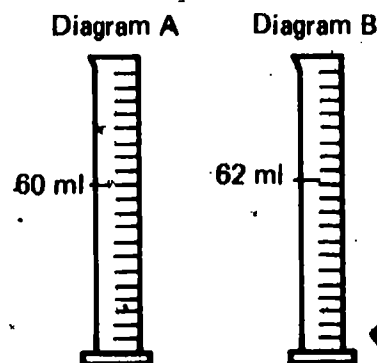

Rub your hands together rapidly. The palms of your hands should feel different after rubbing them.

10-Core-14B

1. If you keep rubbing them, how long will this effect be produced?
2. Explain your answer in terms of the heat-as-energy model.

Assume that the energy within a substance called blog can be measured and that the substance can exist as a solid, a liquid, or a gas, depending on the amount of energy it possesses. Draw a line like the one below on your answer sheet to represent different amounts of energy. Mark the place on this line where you would expect to find each state of the blog, using S for solid, L for liquid, and G for gas.

10-Core-15B

Low energy

High energy

The amount of heat in a pail containing 4,000 ml of water at 35°C is greater than in 50 ml of water at 100°C. Use your heat-as-energy model to explain why this is true.

10-Core-16B

Why does the liquid in the thermometer tube go up and down with temperature changes? Use the heat-as-energy model to explain the movement of the liquid.

10-Core-17B

10-Core-18B

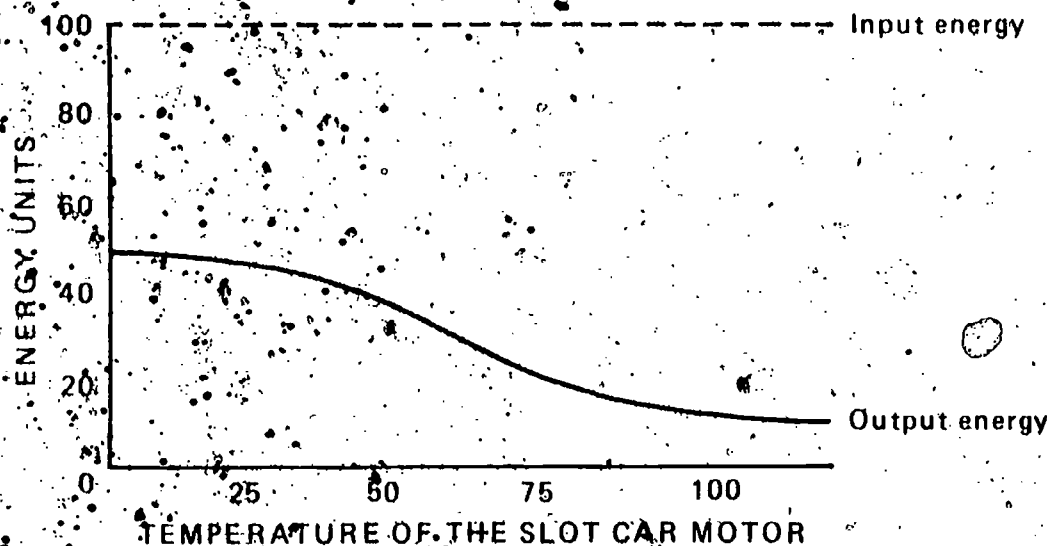

The solid line on the graph above represents the output energy of a slot car motor plotted against the temperature of the motor. The amount of input energy supplied to the motor is a constant 100 units, represented by the dotted line across the top of the graph. Explain what happens to the input energy as the amount of usable output energy decreases.

**10-Core-19B**

In Activity 17-7, diagramed below, you found that the electrical input energy to the motor was greater than the output energy of the motor. Study the diagram below, and use your heat-as-energy model to explain what appears to be a loss of usable energy.

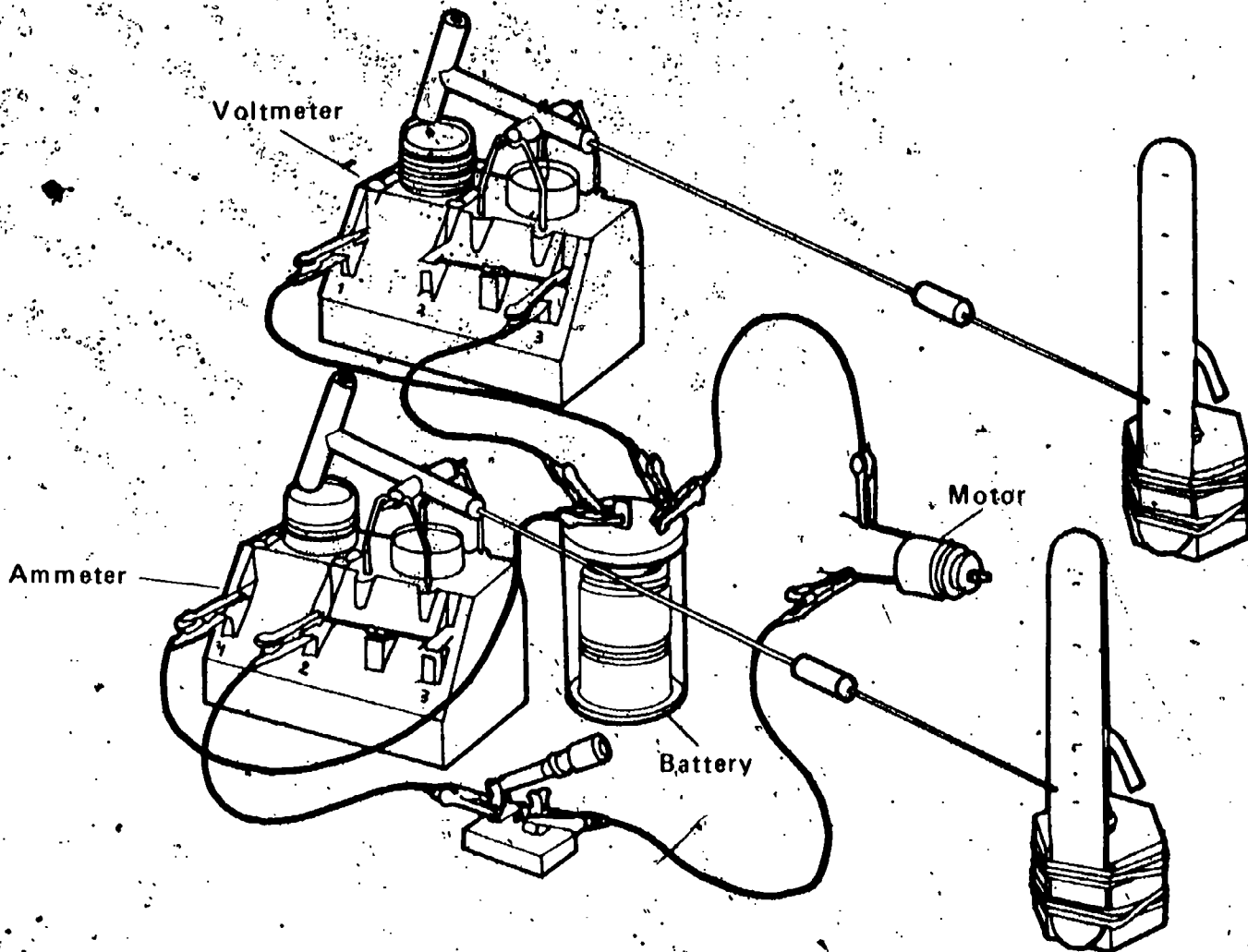

**10-Exc 45-1B**

Daniel and George are camping in a log cabin in the North Woods. They keep a fire going in the fireplace all night. Their beds are bunk style. Daniel sleeps in the upper bunk. Will he be warmer than, just as warm as, or colder than George, who is sleeping in the bottom bunk? Explain your answer.

**10-Exc 46-1B**

A scientific model is discarded when

- a. scientists get tired of it because it has been used for so many years.
- b. new observations produce contradictions within the model.
- c. a model is developed which, though less broad, is easier to understand.
- d. a more complicated, mathematically-based model is developed.

Consider the heating curve for hydrogen fluoride shown in the graph below. Describe the processes that are taking place in sections X, Y, and Z.

10-Exc 47-1B

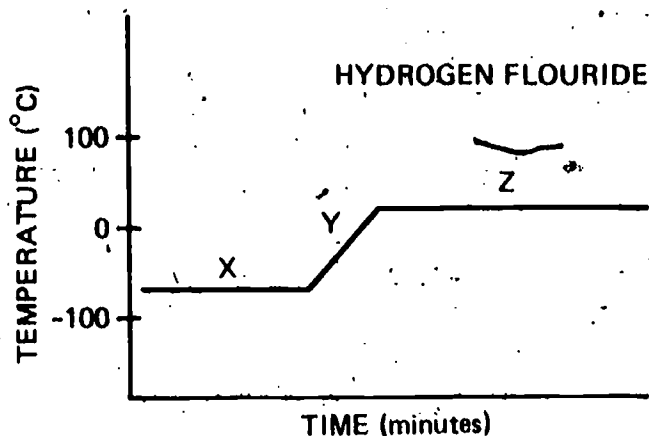

Which of the time-temperature graphs below best describes the cooling behavior of steam when it changes to liquid water?

10-Exc 47-2B

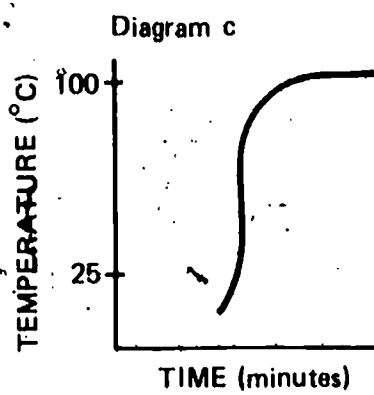
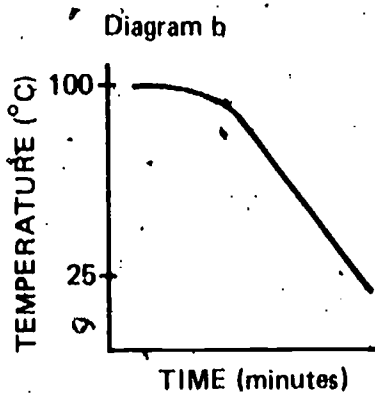
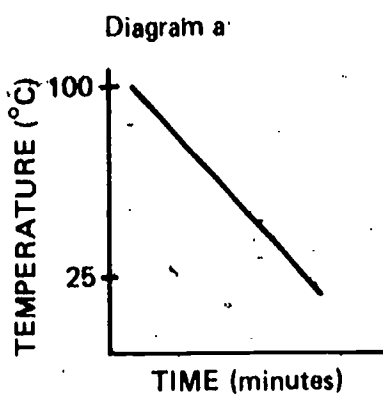

The gasoline in the gas tank of a car has potential energy. When the fuel is ignited in the cylinder, the pistons move up and down in the cylinder. Has all of the potential energy that was stored in the gasoline in the tank been converted to kinetic energy (motion energy)? If not, where did the lost energy go or where did the gained energy come from?

10-Exc 48-1B